

**FOUNDATION
MINI COMPUTER ROOM™**



*120V / 60Hz
230V / 50Hz*

Liebert *Foundation Mini Computer Room* Service Manual

TABLE OF CONTENTS

1.0	Introduction	3
1.1	Basic Components & Options	3
2.0	Liebert Support & Contact Information	4
3.0	Model Number Breakdown	4
4.0	Installation and General Maintenance Recommendations	6
4.1	Ambient Operating Range	6
4.2	Operation & Service Clearance	6
4.3	Airflow Requirements	6
4.4	Periodic Maintenance	6
5.0	Electrical Service Requirements and Connections	7
5.1	Environmental Control Module (ECM) Cooling Options	7
5.2	Liebert Uninterruptible Power System (UPS) Options	7
5.3	Backup Cooling Module (BCM) Cooling Options	7
5.4	FAN Options	7
5.5	No ECM or UPS	7
5.6	Heat Rejection Options	7
5.7	Frame Grounding Lug	7
6.0	Foundation Cooling Systems	8
6.1	ECM Theory of Operation	8
6.1.1	Rack-Mount ECM	9
6.1.2	Top-Mount ECM	9
6.2	ECM with Backup Cooling Operation	10
6.3	ECM with Backup Cooling and Energy Saver Operation	10
6.4	ECM Extension Duct	11
6.4.1	Rack-Mount Extension Duct	11
6.4.2	Top-Mount Extension Duct	12
6.5	Multiple ECM Cooling	12
6.5.1	Dual ECM Barrier	12
6.5.2	Top-Mount ECM Clustering	13
6.5.3	Top-Mount & Rack-Mount ECM	13
6.4	FAN Cooling	13

7.0	Troubleshooting	14
7.1	General Troubleshooting	14
7.2	ECM Factory Settings & Adjustments	15
7.2.1	Thermostat Settings	15
7.2.2	Superseded Thermostat	16
7.2.3	Hot Gas Bypass Valve	16
7.3	Investigating ECM Failure	17
7.3.1	Electrical	17
7.3.2	Removing the Rack-Mount ECM from the Enclosure	17
7.3.3	Removing the Top-Mount ECM from the Enclosure	18
7.3.4	ECM Troubleshooting	19
7.3.5	Removing and Replacing Doors or Side Panels	20
8.0	Schematics and Assembly Drawings	21
8.1	Foundation MCR Single-Line Diagram	21
8.2	ECM Schematic	22
8.3	BCM and Economizer Schematic	23
8.4	SiteNet Integrator Wiring Diagram	24
8.5	ECM Assembly Drawing	25
8.6	BCM Assembly Drawing	26
8.7	Heat Rejection Duct	27
9.0	Parts Lists – 120V 60Hz	28
	Parts Lists – 230V 50Hz	29
10.0	Specification Tables	30
11.0	Start-up Inspection Check Sheet	31

FIGURES

Figure 1	Foundation Mini Computer Room	5
Figure 2	Rack-Mount ECM Airflow Pattern	9
Figure 3	Top-Mount ECM Airflow Pattern	9
Figure 4	Rack-Mount ECM Extension Duct	11
Figure 5	Top-Mount ECM Extension Duct	12
Figure 6	Dual ECM Barrier	12
Figure 7	Clustered Top-Mount ECMs	13
Figure 8	Dual ECMs in a Single Enclosure	13
Figure 9	Thermostat Setpoint	15
Figure 10	Superseded Thermostat	16
Figure 11	ECM Adjustment Points	16
Figure 12	Top-Mount ECM Assembly	18

1.0 Introduction

Liebert has been the world leader in computer support systems for over 35 years. Liebert manufactures precision environmental systems, power conditioning and distribution systems, uninterruptible power supplies, DC power supplies, and remote monitoring and access control systems. Since its founding in 1965, Liebert has developed a complete range of support and protection systems for sensitive electronics.

The Liebert Foundation Mini Computer Room (MCR) continues this tradition. The MCR supersedes Liebert's Little Glass House as today's most complete integrated support system for network hardware and electronic equipment.

The Foundation MCR is an integrated rack enclosure system designed to protect the user's critical network and data processing equipment.

Foundation MCR systems are generally factory configured with an Environmental Control Module (ECM), Liebert Uninterruptible Power Supply (UPS) and/or Liebert SiteNet Integrator monitoring options. By configuring the system with any combination of Liebert ECM Cooling, UPS, or Monitoring systems, Foundation can deliver comprehensive protection to network and computer processing systems. The flexibility of the Foundation allows any Foundation system to be field upgraded by adding doors, side panels, insulation and gasketing, ECM options, and UPS and/or SiteNet Integrator options to provide a complete integrated support system.

1.1 BASIC COMPONENTS AND OPTIONS

MOUNTING FRAME, DOORS & PANELS

The Foundation MCR is built upon a robust Mounting Frame. The frame is heavy duty riveted 12-gauge steel construction and is painted black. Leveling feet which support 2000 lb. of combined MCR and user equipment weight are provided; casters are optional. The front and rear vertical frame members accommodate the Internal Rack-Mounting Rail options and provide space to route and manage customer cabling. Various cutouts for the customer's cable entry are located in the top, bottom and rear of the enclosure; cover plates are provided as sealing and cooling options require. Frames of the same height and depth can be mechanically connected by attaching adjacent frame members to create a larger enclosure system.

Doors, side panels, insulation and gasketing are added to the frame to create a sealed NEMA Type 12 (IP52) enclosure. Options such as an Environmental Control Module, Liebert Uninterruptible Power Supply and/or Liebert SiteNet Integrator (SNI) are added to the sealed enclosure to complete the Mini Computer Room.

ENVIRONMENTAL CONTROL MODULE (ECM) SYSTEMS

The ECM is a self contained, DXAC (direct expansion air-cooled), primary cooling system to provide cooling to customer components inside the Foundation MCR. The ECM is selected and matched to accommodate the user's electronic loads, the heat dissipation of the optional Liebert UPS, and nominal cabinet losses.

BACK-UP COOLING MODULE (BCM)

The BCM is a self-contained back-up cooling system to provide cooling to customer components inside the Foundation MCR. When high temperature is sensed inside the Foundation, the BCM activates and circulates outside air through the enclosure.

UNINTERRUPTIBLE POWER SUPPLY (UPS)

The MCR may be supplied with one of several Liebert UPS units, or with no UPS. For integrated/matched models, the UPS and ECM are normally sized with matched capacities. A larger UPS can be supplied for more battery time, but the connected electronics load should not exceed the ECM rating. For MCR models supplied with a UPS, refer to the separate UPS manual for operation and specifications.

MONITORING OPTIONS

The SiteNet Integrator is a separate rackmount unit that communicates status of the UPS and MCR. The option consists of a SiteNet Integrator module that is typically mounted in the top of the MCR cabinet. The SiteNet Integrator is available with any combination of the following options. For MCR models supplied with a SNI, refer to the separate SNI manual for operation and specifications.

- Door Ajar
- Temperature and Humidity Sensors (Internal and External)
- Water Detector
- Smoke Detector

All the components and options listed above are available factory-installed at the time of order. Many options are also available for field installation. Field installed options are shipped as kits containing the sensors with appropriate mounting hardware, cable, and cable restraint fixtures. Field installation requires hand tools for termination of control cables and routing of the cables.

2.0 Support & Contact Information

For technical support on the Liebert Foundation MCR, dial 1 800 222-5877, ext. 32, or (614) 841-5492. Liebert DPG Application Engineers can be reached 7 x 24 at these numbers. You may also e-mail the applications group at upstech@liebert.com.

To visit the Liebert web site, go to www.liebert.com. User's manuals, technical specifications and drawings can be downloaded from the Liebert website. From the Liebert home page, proceed to the "Enclosure Systems" link for information about the Foundation.

The Foundation MCR may include Liebert Site I.D. and/or Tag Numbers, indicating that the unit is under contract with Liebert Global Services. In this case please contact Liebert Global Services at 1 800 LIEBERT (1 800 543-2378).

Please be sure to include the model number and serial number of the Foundation MCR enclosure on all invoices returned to Liebert Corporation in order to complete processing. The model number and serial number for the Foundation MCR is located on the inside of the front-left vertical frame. Warranty coverage is subject to Liebert verification of the claimed defect and/or an inspection of the Liebert product shows no sign of misuse, improper application, or installation contrary to Liebert's recommendations or specifications. All defective products and component parts replaced under this warranty become the property of Liebert. Refer to separate warranty statement for details.

3.0 Model Number Breakdown

Example, System Model Number = HD780CCC0Kxxxxx:

HD	780	C	C	C	0	K
Enclosure Width/Type	Enclosure Height/Depth	Primary Cooling	Back-up Cooling	UPS Type	Monitoring Option	Input Power
H = 19" Rack R = 23" Rack	44" Height 78" Height 84" Height	0 = None 1 = FAN1000L 2 = FAN1000H 3 = FAN2000L 4 = FAN2000H	0 = None A = BCM1000L B = N/A C = BCM2000L	0 = None A = GXT2-1000 B = GXT2-1500 C = GXT2-2000 D = GXT2-3000 E = GXT2-700 F = PS1000RT2 G = PS1440RT2 H = PS2200RT2 I = PS3000RT2 K = GXT2-2700* L = GXT2-6000*	0 = None 1 = SNI-SE 2 = SNI-SE + LCM 4 = LCM Only	K = 120VAC 60HZ S = 230VAC 50HZ
D = Sealed K = Non-Sealed	0 = 30" Depth 8 = 38" Depth	5 = XDA5B (1) 6 = XDA5B (2) A = ECM1000LR B = ECM1000LT C = ECM2000LR D = ECM2000LT				
		H = High Ambient L = Low Noise R = Rack-Mount T = Top-Mount		* = 208VAC	SE = Ethernet	

FIGURE 1 - FOUNDATION MINI COMPUTER ROOM

SiteNet Integrator (Option)

Backup Cooling Module (Option)
Rear Door Mount only

Customer
Equipment



UPStation GXT2U UPS (Option)

Environmental Control Module
(Rack Mount model shown, Top Mount available)

4.0 Installation and General Maintenance Recommendations

For optimum performance, the Foundation MCR Enclosure should remain closed and sealed off from external environmental conditions. To maintain these conditions, cables should be routed into the provided entrance points in the enclosure during installation, while maintaining the integrity of the enclosure's seals. Cable entrapment in the doors, non-sealed cable entrance points, and non-sealed doors or side panels will cause external environmental conditions to impact performance and reduce the system's reliability.

4.1 AMBIENT OPERATING RANGE

The external ambient operating range of the ECM is as follows:

120V 60Hz ECM - 65°F (18°C) to 105°F (40°C).

230V 50Hz ECM - 65°F (18°C) to 100°F (38°C).

4.2 OPERATING CLEARANCE REQUIREMENTS

4.2.1 Service Requirements - All MCR systems require 3'0.9m of clearance in the front of the unit for ECM service access.

4.2.2 Rack-mount ECM - MCR systems utilizing rack-mount ECM cooling options require a minimum of 1'0.3m airflow clearance about the front, rear and top of the Foundation MCR enclosure. No side clearance is required.

4.2.3 Top-mount ECM - MCR systems utilizing top-mount ECM cooling options require a minimum of 1'0.3m airflow clearance about the front, rear, top, and each side of the top-mount ECM.

4.2.4 Optional BCM - MCR systems utilizing optional Backup Cooling Module options require a minimum of 1'0.3m airflow clearance from the rear of the BCM. No side clearance is required.

4.2.5 Optional BCM Energy Saver - This option requires 3'0.9m of clearance in the rear and 2'0.6m of clearance on the sides of the enclosure. If these clearances are not available the Energy Saver Control module can be relocated to allow for more accurate ambient readings.

4.3 AIRFLOW REQUIREMENTS

Liebert offers two heat rejection options to assist in the removal of rejected ECM heat from spaces or alcoves without adequate building ventilation.

4.3.1 Heat Rejection Fan - This field-installed package includes a combination blower with inlet air louver plate. The package requires installation in a tile/grid type ceiling, and allows for connection of customer-supplied 8" diameter exhaust duct (if required). The option includes installation instructions.

4.3.2 Heat Rejection Duct - This field-installed option includes a flexible round duct, which is 12 feet long, and 8 inches in diameter. The duct is attached directly to the enclosure at the ECM discharge, and terminated as required per site. A booster fan is included to overcome duct static pressure. This option is applicable only to Rack-mount ECMs. Refer to drawing in section 8.7.

4.4 ECM PERIODIC MAINTENANCE

The ECM blower assemblies do not require lubrication. The condenser coil fins should be inspected periodically to determine the necessary cleaning interval based on conditions at the installation site. Depending on site conditions the coil fins may require cleaning as often as twice a month or as seldom as twice per year. The condenser is located at the front of the ECM.

If the fins become dirty and clogged, they should be gently vacuumed with a soft bristle brush, or cleaned with compressed air. To access the condenser in rack mount units, open the front door of the Foundation MCR and remove the two retaining bolts from the inside of the front access plate at the bottom of the rack. The bolts require a 10mm socket or wrench. The plate will swing down freely once the bolts are removed. After cleaning, swing the access plate back into position and replace the two bolts. For Top mount ECM units, remove the sheetmetal cover from the ECM to access the coil.

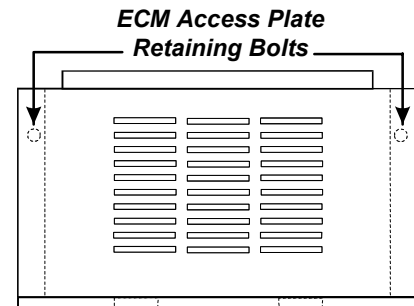

5.0 Electrical Service Requirements and Connections

The Foundation MCR is equipped with separate input cords for the ECM and the optional Liebert UPS. The ECM and the optional UPS each must be connected to separate dedicated circuits. Input power requirements of each component are described below.

5.1 ECM COOLING OPTIONS:

All ECM options include a single 9'2.7m input power cord. This is the only power connection required for the ECM.

120VAC Nominal (+10%, -15%), 60Hz.

Models ECM1000L-x60, ECM2000L*-x60, ECM1000H*-x60, ECM2000H*-x60:*

NEMA 5-15R, single-phase 2-wire plus ground 15A dedicated circuit.

230VAC Nominal (+10%, -15%), 50Hz.

Models ECM1000L-x50, ECM2000L*-x50, ECM1000H*-x50, ECM2000H*-x50:*

Single-phase 2-wire plus earth 10A dedicated circuit. The 50 Hz ECM plug connection is field-supplied and installed.

* = T (Top-Mount) or R (Rack-Mount).

x = C (Carrier compressor) or T (Tecumseh compressor).

5.2 LIEBERT UPS OPTIONS:

120VAC Nominal

PS1000, PS1440, GXT1000, GXT1500, GXT2-1000, GXT2-1500:

NEMA 5-15R, single-phase 2-wire plus ground 15A circuit.

GXT2000, GXT2-2000: NEMA 5-20R, single-phase 2-wire plus ground 20A circuit.

PS2200, PS3000, GXT3000, GXT2-3000: NEMA L5-30R, single-phase 2-wire plus ground 30A circuit.

230VAC Nominal

PS1000, PS1440, GXT1000, GXT1500, GXT2-1000, GXT2-1500: single-phase 2-wire plus ground 10A circuit.

PS2200, PS3000, GXT2000, GXT3000, GXT2-2000, GXT2-3000: single-phase 2-wire plus ground 16A circuit. All 230VAC UPS connections are field-supplied and installed.

NOTE: GXT2 model numbers superseded the GXT models in September 2001.

5.3 BACKUP COOLING MODULE (BCM)

OPTIONS:

BCM Options are factory-installed and connected to the optional UPS. Where the Foundation MCR is not equipped with a UPS, the input connection is field supplied. The BCM Cooling Options require either a NEMA 5-15R (120VAC, 60Hz) or IEC60320 C14 (230VAC, 50Hz) circuit.

5.4 FAN-ONLY OPTIONS:

Foundation Enclosures are available with optional FAN cooling, which is used in lieu of ECM and BCM cooling options. The 60Hz fans are rated 120VAC and include 15'4.5m power cords with NEMA 5-15P plug(s). The 50 Hz fans are rated 230 VAC and include 15'4.5m power cord(s); plug connection is field-supplied and installed.

5.5 NO ECM OR UPS OPTIONS:

The Foundation is configurable with no ECM or UPS options. When the product is configured without these options, the input power specifications are determined by the FAN system, optional power strip(s), and/or user-supplied equipment.

5.6 HEAT REJECTION OPTIONS

Heat Rejection Fan - Electrical connection is hardwired. The ECM Heat Rejection Fan options require a 120VAC, 15A, 60Hz or 230VAC, 10A, 50Hz circuit.

Heat Rejection Duct - Powered by customer connection to 120VAC, 15A, 60Hz circuit (NEMA 5-15). A single 15'4.5m power cord with NEMA 5-15P plug is included.

5.7 FRAME GROUNDING LUG

A grounding lug is provided at the bottom of the MCR frame and can be relocated to the top of the frame by the customer if required. The grounding lug accepts wire sizes up to 1/0 AWG/35mm² max. and is supplied for use as required by customer equipment. The Liebert ECM, UPS and BCM options do not use the frame grounding lug.

6.0 Foundation Cooling Systems

6.1 ENVIRONMENTAL CONTROL MODULE (ECM) - THEORY OF OPERATION

The ECM cooling option is applicable only to Foundation Mini Computer Room (MCR) enclosures. These enclosures are sealed to meet the requirements of NEMA 12 / IP52 and are designated as "HD" or "RD" in the system part number. Cabinets that leave the factory as non-sealed enclosures are designated as "HK" or "RK" in the system part number; these units require field-installation of the Liebert NEMA 12 sealing kit to accept ECM cooling options. Contact Liebert DPG Applications for details.

The ECM is a self contained, DXAC (direct expansion air-cooled), primary cooling system to provide cooling to customers' components inside the Foundation MCR. Two independent air paths circulate cool air inside and reject equipment heat to outside the enclosure (See Figure 2). A hot gas bypass provides automatic load matching and enhanced ECM life. The compressor is protected by an integral overload sensor (there is no external reset) and a 2-minute time delay relay, refer to the ECM Schematic, Fig 8.2. A thermostat is mounted in the ECM's evaporator return airstream. All systems utilize "green" R-407C refrigerant.

The ECM starts upon application of power to the ECM input power cord. The thermostat controls the cut-off temperature of the ECM compressor and condenser fan. The thermostat is factory set for cut-off at 75°F. The ECM provides cooling when the internal cabinet temperature is greater than 75°F. Below 75°F, the ECM evaporator fan continues to circulate air inside the enclosure. The thermostat will not normally require user adjustment.

The Hot Gas Bypass Valve is located on the left-hand side of the ECM approximately halfway between the front and rear of the unit, and is accessible by removing the rubber grommet on the side of the ECM. The system bypasses hot gas around the condenser to minimize cycling of the compressor and provide capacity control. Refer to section 7.2 for details on thermostat and hot gas bypass factory setpoints and adjustments.

An ECM Control Cable is located in the rear left corner of the ECM. The standard control cable connector supplied with the ECM includes an internal jumper between pins 1 and 2 and an extended cord providing 24 VAC output on pins 3 and 4. The jumper between pins 1 and 2 is required to energize the compressor. The extended cord provides 24 VAC to the optional Liebert monitoring devices, if installed. The wiring is not polarity sensitive. If no monitoring devices are installed, the cord is wound and tied off for possible future installation of these options. When a Backup Cooling Module (BCM) is included, a separate Control Cable is supplied to connect the ECM and BCM. Refer to the parts list in section 9 for these part numbers.

The ECM features low noise operation suitable for use in occupied spaces, and an automatic condensate re-evaporation system. No condensate drain connection is required under normal conditions. All ECMs are fitted with a 3/8" copper condensate drain tube. If the ECM is operated for extended periods with open doors or extensive violations of the enclosure's seal, this tube will route excess condensate out the rear of the enclosure.

ECM cooling capacities are as follows:

ECM1000 provides adequate cooling for electronic loads up to 824 watts (including UPS).

ECM2000 provides adequate cooling for electronic loads up to 1647 watts (including UPS).

For detailed information, refer to Specifications in Section 10.

6.1.1 Rack-Mount ECM

Rack-mounted ECMs are factory-installed and ship inside the enclosure. All Rack-Mount ECMs fit into the EIA310 standard for 19" racks and require 12.25" / 31.1cm / 7U rack space. For 23" rack enclosures, 23"-19" adapter plates are provided.

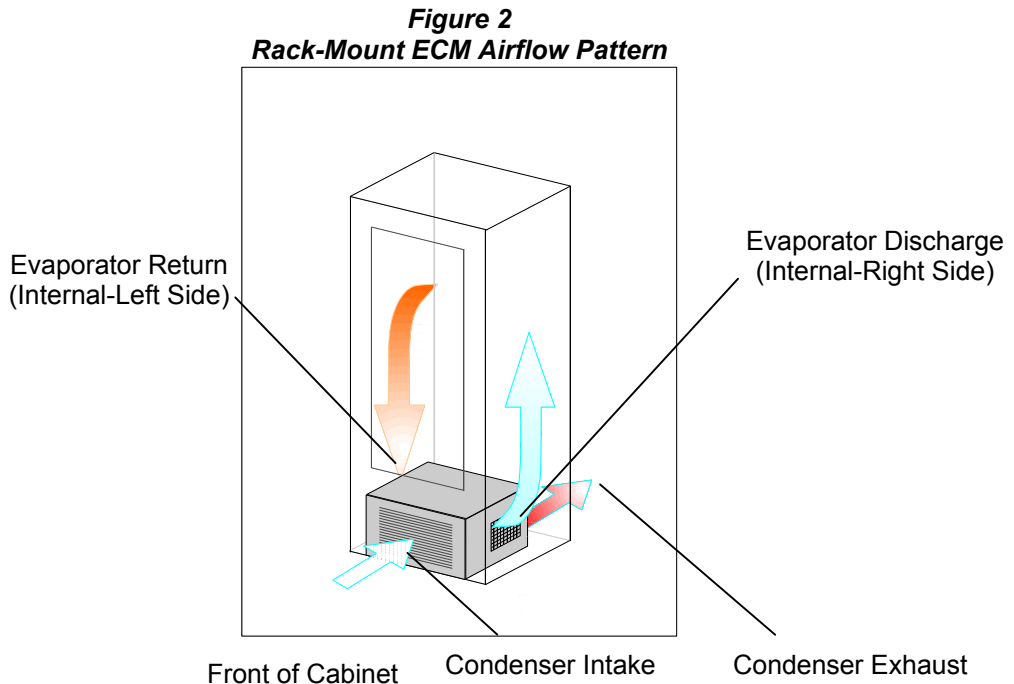

6.1.2 Top-Mount ECM

The ECM is also available as an external Top-Mount version. Top-Mount ECMs ship separate for field installation. All Top-Mount ECMs include an Interface Plenum that mounts on top of the Foundation MCR enclosure immediately under the ECM. The Interface Plenum directs the ECM evaporator discharge and return airstreams through the enclosure (See Figure 3). Additionally, the Plenum acts as a buffer to prevent excess condensate runoff from entering the Foundation MCR enclosure. The Top-Mount ECM otherwise maintains all features, benefits and cooling capacity of the comparable Rack-Mount ECM.

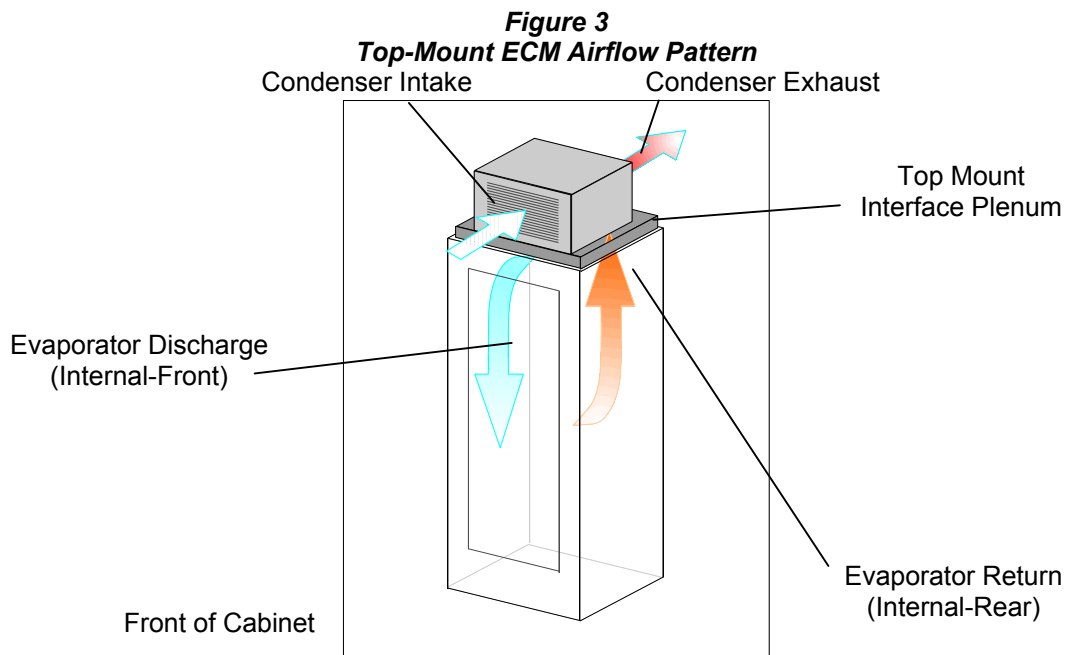

6.2 ECM WITH BACK-UP COOLING OPERATION

The Backup Cooling Module (BCM) is an optional self-contained fan and filter system to provide cooling to customers' components inside the Foundation MCR. The BCM is factory-mounted on the enclosure rear door. Back-Up Cooling requires the High Temperature Alarm Module option.

Under normal conditions, the ECM acts as the primary cooler for the enclosure and the BCM fans are not active. The cabinet seal is maintained by magnetic gasketing on the BCM intake and exhaust damper doors; solenoids drive each door open during Back-Up Cooling operation. Back-Up Cooling starts automatically when the High Temperature Alarm Module detects an internal cabinet temperature of 100 °F. The sensor is located on the High Temperature Alarm Module at the top left-hand side (as you face the rear of the cabinet). An audible alarm will sound until the cabinet temperature decreases below 100 °F or is silenced by depressing the Alarm Silence switch on the High Temperature Alarm Module. The BCM circulates filtered outside air through the enclosure. The BCM is normally powered from the cabinet-mounted UPS, but could also be powered from a source outside the cabinet.

A Control Cable connects the BCM to the High Temperature Alarm Module. The cord marked "37/38" connects to pins 1 and 2 in the BCM and extends to the High Temperature Alarm Module terminals "T2" and "T3" (N.O. 100 °F contact). The cord marked "24 VAC" supplies input power to the High Temperature Alarm Module at terminals "T7" and "T8". For detailed information, refer to section 8.3, BCM/Economizer schematic.

6.3 ECM WITH BACK-UP COOLING ENERGY SAVER OPERATION

The BCM Energy Saver Control is an add-on device that provides energy cost savings by allowing the BCM to operate as the primary enclosure cooler. If the interior and exterior ambient conditions are suitable, the Energy Saver option will disable the cabinet ECM and enable the BCM system to draw exterior filtered air into the cabinet for use as the primary cooling. An enthalpy controller is used to detect the exterior cabinet ambient conditions.

The High Temperature Alarm Module monitors the interior cabinet temperature and if the interior temperature is less than 90 °F and the enthalpy control recognizes that exterior conditions are suitable, the ECM is disabled and the BCM activates as the primary cooler. If the cabinet temperature increases above 90 °F, the BCM is disabled for a period of one hour and the ECM is enabled to supply cabinet cooling. The one-hour time-out prevents cycling of the ECM & Energy Saver. If the interior cabinet temperature reaches 100 °F, the Back-Up Cooling will start and operation will be as described in 6.2.

The Back-Up Cooling Energy Saver option includes the externally mounted Enthalpy Controller and a 3-socket Control Harness. The Enthalpy Controller is mounted on the outside of the rear door underneath the BCM. The Control Harness connects the Enthalpy Controller to the High Temperature Alarm Module terminals "T1" and "T4". A cable assembly connects the BCM and the ECM. A cable from the BCM connector provides 24VAC to the High Temperature Alarm Module terminals "T7" and "T8". A cable from BCM connector connects to the High Temperature Alarm Module terminals "T2" and "T3". For detailed information, refer to section 8.3, BCM/Economizer schematic. The factory set point for the enthalpy control is the "A" setting.

ECM / BCM/ Energy Saver Cooling System Operation Table			
External Ambient Conditions	Internal Temp ≤ 90° F	Internal Temp 90° F - 99° F	Internal Temp ≥ 100° F
External Temp < 68° F and Rel. Humidity < 60%:	<i>Energy Saver Cooling</i>	<i>ECM Cooling</i>	<i>Back-Up Cooling (High Temperature Alarm Sounds)</i>
External Temp > 68° F and Rel. Humidity > 60%:	<i>ECM Cooling</i>	<i>ECM Cooling</i>	<i>Back-Up Cooling (High Temperature Alarm Sounds)</i>
<i>Tolerance ± 4° F and ± 8 % R.H.</i>			

6.4 ECM EXTENSION DUCT

If a customer's equipment will not fit into a single cabinet, they can add an additional cabinet to the main cabinet. Cabinets of the same height and depth can be mechanically connected by attaching adjacent frame members to create a larger enclosure system. In this configuration, the ECM Extension Duct is required for distribution of cool ECM air from a MCR with ECM to an adjacent MCR without an ECM (i.e. main ECM enclosure and non-ECM extension enclosure). A single ECM can provide cooling for a maximum of (2) MCR cabinets – one main unit and one extension unit. Use of the ECM Extension Duct does not increase the total cooling capacity of the ECM. ECM Extension Ducts are field-installed and attached to the right side of the ECM (see Figures 4 & 5). The maximum ambient operating range of the ECM is reduced by 5°F (2.7°C) when an extension cabinet is added to the system.

6.4.1 Rack-Mount ECM Extension Duct

For Rack-Mount ECM applications the extension duct is located at the bottom of the enclosure and is 5.25" / 13.4 cm / 3U tall. A transition duct is included in the package and connects the ECM to the extension duct in the adjacent cabinet. The transition duct and extension duct must be field-installed after the enclosures are rolled into place. See Figure 4.

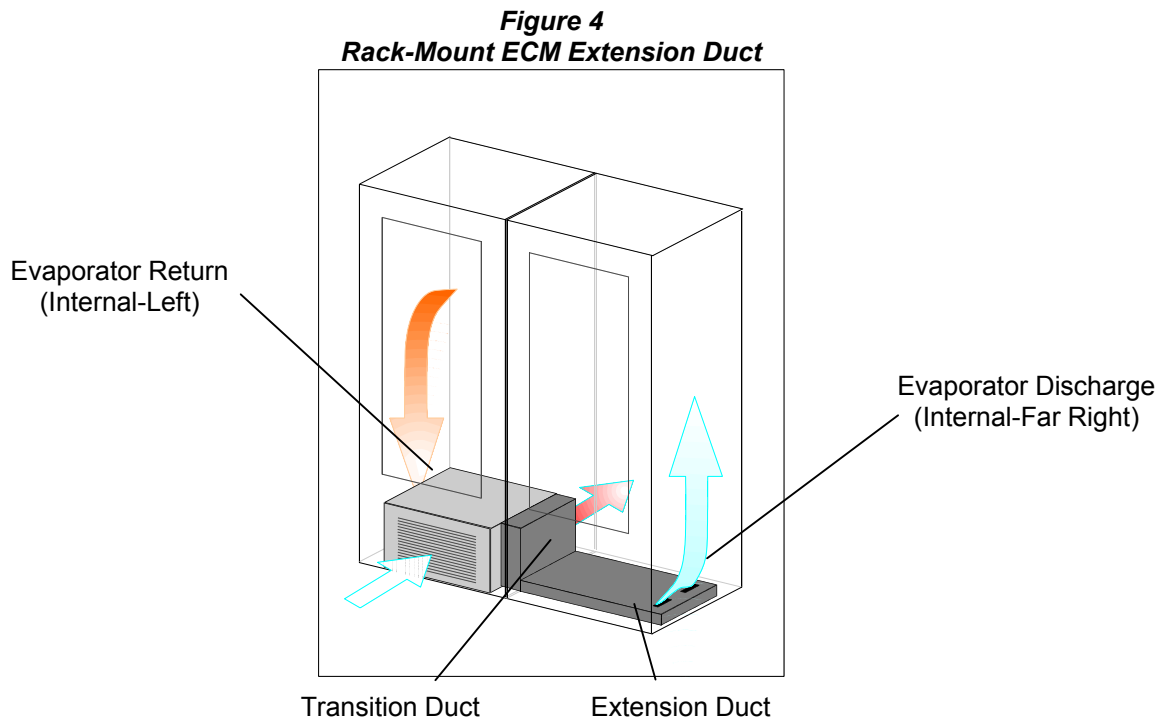

6.4.2 Top-Mount ECM Extension Duct

For Top-Mount ECM applications the extension duct is insulated, and field-installed outside the enclosure. The Top-Mount extension duct interfaces with the Interface Plenum that is included with the Top-Mount ECM. See Figure 5.

Top-Mount extension cabinets require relocation of the BCM high temp thermistor.

The thermistor is factory-installed in the upper right side of the ECM cabinet. For all Top-Mount extension applications, the thermistor must be relocated to the upper right of the extension cabinet.

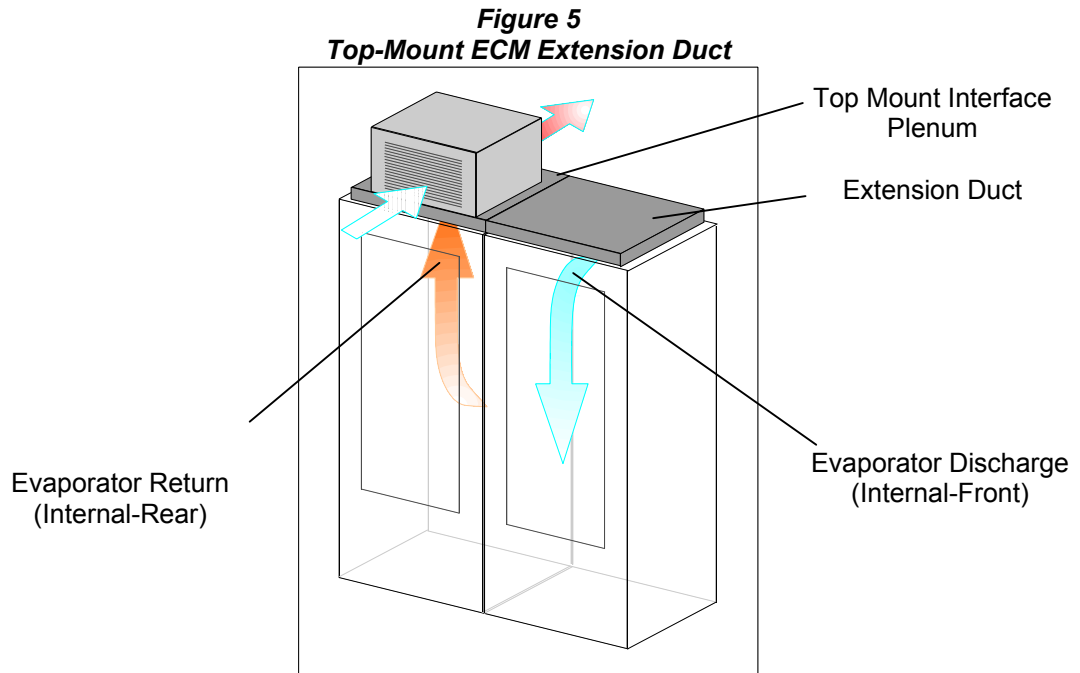

6.5 MULTIPLE ECM COOLING

The Foundation MCR is able to accommodate loads exceeding the parameters in 6.1 via the application of additional ECMs. Foundation MCR enclosures may be clustered together, with each enclosure utilizing an ECM, or one Rack-Mount and one Top-Mount ECM may be applied to a single Foundation MCR.

6.5.1 Dual ECM Barrier

When clustering enclosures with more than one Rack-Mounted ECM, a Dual ECM Barrier is required between adjacent ECMs. The Dual ECM Barrier allows two Foundation MCRs, each with ECM, to be attached together without a side panel on adjoining sides. The barrier is sheetmetal, attaches to the bottom of the mounting rail, and prevents the cold air discharge from the left ECM from impacting the return air intake on the adjacent ECM. For optimum performance, the load in each cabinet should be distributed according to the capacity of the ECM in each cabinet.

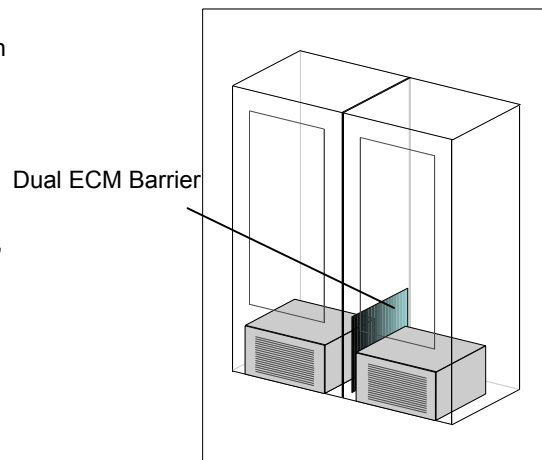

Figure 6 – Dual ECM Barrier
Clustered Rack Mount ECMs

6.5.2 Top-Mount ECM Clusters

When clustering enclosures with more than one Top-Mounted ECM, a Dual ECM Barrier is not required between adjacent ECMs. Each ECM requires an Interface Plenum that mounts on top of the Foundation MCR enclosure immediately under the ECM as described in 6.1.2. Each Interface Plenum is independent. For optimum performance, the load should be distributed according to the capacity of the ECM in each cabinet.

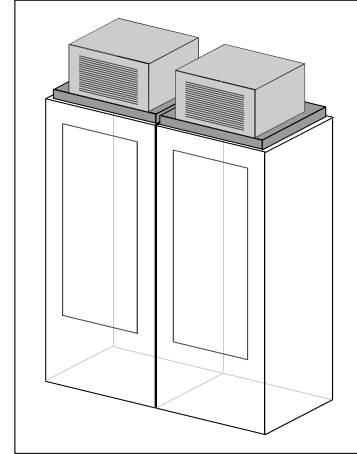

Figure 7 - Clustered Top Mount ECMs

6.5.3 Top-Mount / Rack-Mount ECM

For maximum cooling in a single enclosure, one Rack-Mount and one Top-Mount ECM may be applied to a single Foundation MCR. A Dual ECM Barrier is not required for single cabinet configurations, however the Interface Plenum is required for the Top-Mounted ECM.

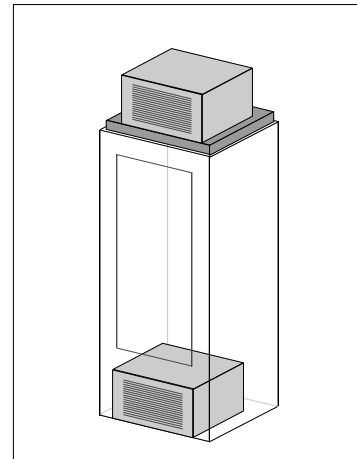

Figure 8 - Dual ECMs in a Single Enclosure

6.6 FAN COOLING

Foundation Enclosures are available with optional FAN cooling, which is used in lieu of ECM and BCM cooling options. Foundation Enclosures with FAN cooling are typically furnished without panel insulation and sealing gaskets (i.e. non-sealed enclosure). The FAN options are a one fan (FAN1000) or two fan (FAN2000) kit, in either “low noise” or “high ambient” versions. Fan(s) may be installed in cutouts on the enclosure’s top plate, or relocated to rear-panel access holes above the door. Up to 5 fans may be installed into the enclosure’s top and rear plates. Block-off plates are provided to enhance air circulation. A FAN Filter is optional; filters are factory-installed at the bottom of the front and rear doors. FAN capacities are:

FAN1000 provides a fan rated for 114 CFM (60Hz) or 94 CFM (50Hz) for “low noise” option and 235 CFM (60Hz) or 200 CFM (50Hz) for “high ambient” option.

FAN2000 provides two fans each individually rated for 114 CFM (60Hz) or 94 CFM (50Hz) for “low noise” option and 235 CFM (60Hz) or 200 CFM (50Hz) for “high ambient” option.

7.0 Troubleshooting

7.1 GENERAL TROUBLESHOOTING

Troubleshooting the MCR is similar to troubleshooting other Liebert environmental systems, except that the cooling systems are installed in a self-contained rack. The information below describes various symptoms a user may encounter in the event the Foundation MCR™ develops a problem. Use this information to determine whether external factors cause the problem and how to remedy the situation.

SYMPTOM: ECM IS NOT COOLING OR CABINET IS HOT

- 1. Check if the condenser coil is clogged or needs cleaning.** (See Periodic Maintenance, section 4.0).
- 2. Check clearances around cabinet.** Check that the unit has at least one foot of clearance in front of, behind and above the cabinet, and that the condenser airstream is not compromised. Make sure that the unit is not directly beneath a heating duct. If the unit is installed in a closet, alcove, or enclosed area without building ventilation, a heat rejection option may be required to move rejected ECM heat out of the confined area.
- 3. Verify that the evaporator discharge and return is not blocked.** Check for airflow obstructions inside the bottom of the cabinet such as manuals, cables, etc.
- 4. Confirm that the ECM is connected to the proper electrical service.** The internal evaporator airflow fan will operate whenever the ECM is receiving AC power. The evaporator fan will continually circulate internal air through the cabinet, even when the compressor has cycled off. If the evaporator fan is not running, verify that the unit is connected to the proper electrical service. (See Electrical Service Requirements, section 5.0).

Removing and Re-applying Power: The ECM compressor is protected by a 2-minute time delay relay. If power is removed while the refrigerant circuit is operating, 2 minutes must pass before the refrigerant circuit will restart. Two minutes after power is restored & if the internal temperature is above 75°F (23.8°C), the cooling circuit should restart. Longer delays may indicate an internal ECM fault.

- 5. Check for open doors, and gaps in side panels or cable entrance points.** Direct ambient heat loading through an open door, or cable entry points etc. can overload the ECM. See item 1, next page.
- 6. Verify that the ECM or BCM Control Cable is Installed.** The ECM control cable must be installed on the rear of the ECM in order for the ECM to provide cooling. The control cable also interfaces the ECM with the BCM and High Temperature Alarm Module when these options are installed.
- 7. Verify that the ECM is not overloaded.** ECM1000 series should be matched to a combined total UPS and equipment load of 1000VA or smaller (up to 824W), the ECM2000 series should be matched to a combined total UPS and equipment load of 1000VA to 2000VA (up to 1647W). In multiple ECM configurations, the load should be distributed according to the capacity of the ECM in each cabinet.
- 8. Check positioning of equipment inside the enclosure.** Equipment dissipating the most heat should be located as close to the ECM as possible. To promote proper airflow patterns, any unused rack space should be at the end of the rack that is opposite the ECM. Check for open spaces between rack-mounted equipment that may be short-cycling the ECM airflow; advise the user of the need to reposition any equipment in order to enhance internal airflow.
- 9. Check exhaust ducts for proper airflow.** Directly connected heat rejection ducts must include fans or a booster blower with the capacity to overcome the static pressure in the duct. The ECM's condenser fan is not designed to overcome the static pressure of an external exhaust duct. The discharge from two or more cabinets should not be routed into the same duct unless the blower has been sized with enough capacity to overcome the combined total static pressure of each duct.

SYMPTOM: HIGH TEMPERATURE AUDIBLE ALARM AND BACK-UP COOLING MODULE IS OPERATING

The HTAM (High Temperature Alarm Module) is located on the top/left of the frame (facing the rear of the cabinet) and can be accessed through the rear door of the cabinet. The Alarm Silence button is located on the HTAM. If the cabinet is NOT generally hot, check if the HTAM sensor is located in a hot spot, such as near the exhaust of a server or above a monitor. The sensor is permanently connected to the HTAM via a 2' (61cm) white cable. The sensor can be relocated to detect a more average temperature location. If the sensor is not located in a hot spot, check the "ECM not Cooling" symptom above.

SYMPTOM: WATER IS LEAKING FROM THE CONDENSATE DRAIN

1. Check for violations to the seal of the cabinet. Wiring and cables should not be trapped in the doors and prevent the doors from closing properly. Cables should be routed into the provided Sealed Entrance Cable Raceway on the rear of the unit, or routed into an optional Sealed Entrance Cable Bundle. The Sealed Entrance Cable Bundle is a rubber grommet and insulation package that is installed into the round cable access holes in the top or bottom of the cabinet.

If an air leak is suspected, the tissue technique can be used to check the door and panel gasketing. Slowly moving a tissue around the edges of the doors and panels can reveal a damaged gasket. If the tissue is sucked into or blown away from the cabinet, check the gasketing in the area to confirm it is intact. Damaged or missing gasketing should be repaired or replaced.

2. Excessive Opening of Doors. Operating the ECM with doors or panels open will overload the condensate re-evaporation system in the ECM. Depending on ambient conditions, the condensate re-evaporation system may reach full capacity in 5 minutes to 20 minutes.

3. Check exhaust ducts for proper airflow. Directly connected heat rejection ducts must include fans or a booster blower with the capacity to overcome the static pressure in the duct. The ECM's condenser fan is not designed to overcome the static pressure of an external exhaust duct. The discharge from two or more cabinets should not be routed into the same duct unless the blower has been sized with enough capacity to overcome the combined total static pressure of each duct.

7.2 ECM FACTORY SETTINGS & ADJUSTMENTS

If the above checks (section 7.1) do not resolve the problem, check the hot gas bypass valve and return air stat settings. There are two different thermostats used in Foundation ECMs. The current thermostat was implemented to production in Feb 2004 and is part number 163541P1. Part number 138164P1 is no longer in use. The factory set point and the adjustments for each are described below.

7.2.1 Factory Setting –Thermostat (163541P1):

This is a SPST thermostat with a range of 65°F-95°F and a 5°F differential. It can be identified via the part number 163541P1. This stat more accurately governs operation under typical application conditions. Facing the rear and viewing the top of the ECM, the factory setting is when the flat cutaway side of the shaft is perpendicular to 1:00 (75°F) as shown below. Turning the stat CCW raises the cut-off temperature of the compressor. CW rotation lowers the cut-off temperature of the compressor.

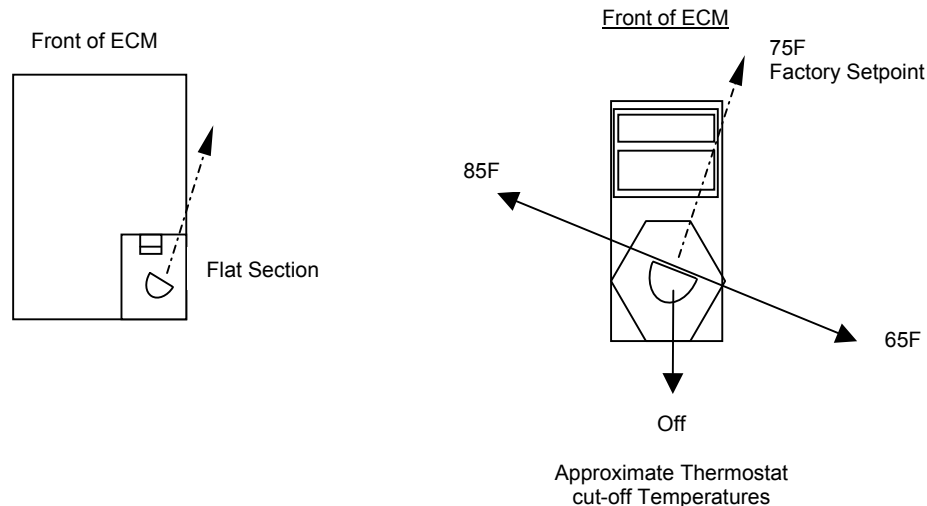

Figure 9 –Thermostat Setpoint

CAUTION: Reducing the compressor cut-off temperature may result in the formation of ice on the evaporator coil and/or condensation on the MCR doors and panels. Be sure that the condenser coil is clean and that the ECM is not overloaded before adjusting the ECM thermostat. Please consult Liebert Applications Engineering if adjustment is necessary.

7.2.2 Factory Setting – Obsolete Thermostat (138164P1):

This is a SPST thermostat with a range of 50°F-80°F and a 5°F differential. This stat was replaced by part number 163541P1 in Feb 2004. Facing the rear and viewing the top of the ECM, the factory setting is when the flat cutaway side of the shaft is perpendicular to 9:00 (75°F) as shown below. Turning the stat CCW raises the cut-off temperature of the compressor. CW rotation lowers the cut-off temperature of the compressor.

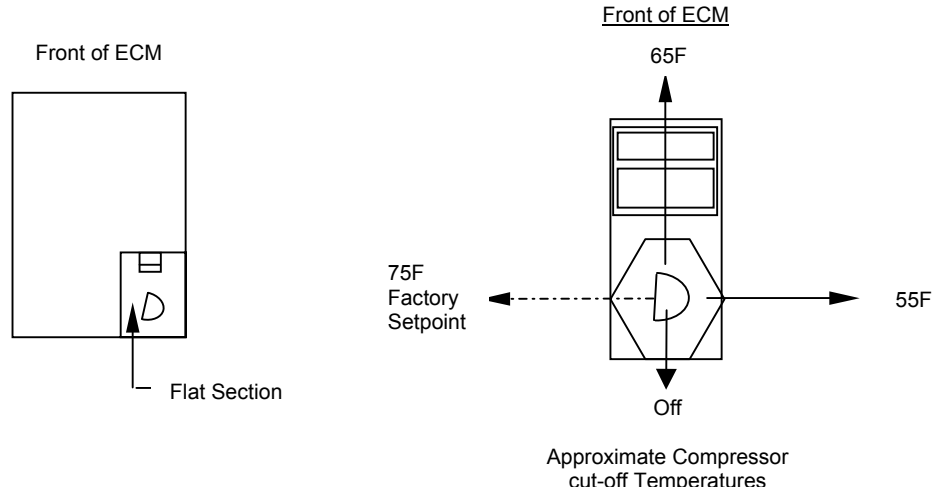

Figure 10 – Obsolete Thermostat

7.2.3 Factory Setting - Hot Gas Bypass Valve:

All ECM2000L series: 2 turns CCW from full CW position.

All ECM1000L series: 1 1/4 turns CCW from full CW position.

Clockwise rotation will add hot gas. Turning the valve counter-clockwise adds more capacity (cooler air). Adjustment to the valve requires a 3/8" socket.

CAUTION: If the Hot Gas Bypass Valve is turned too far, icing on the evaporator coil may result. Be sure that the condenser coil is clean and that the ECM is not overloaded before adjusting the Hot Gas Bypass Valve. Please consult Liebert DPG Applications Engineering if adjustment is necessary.

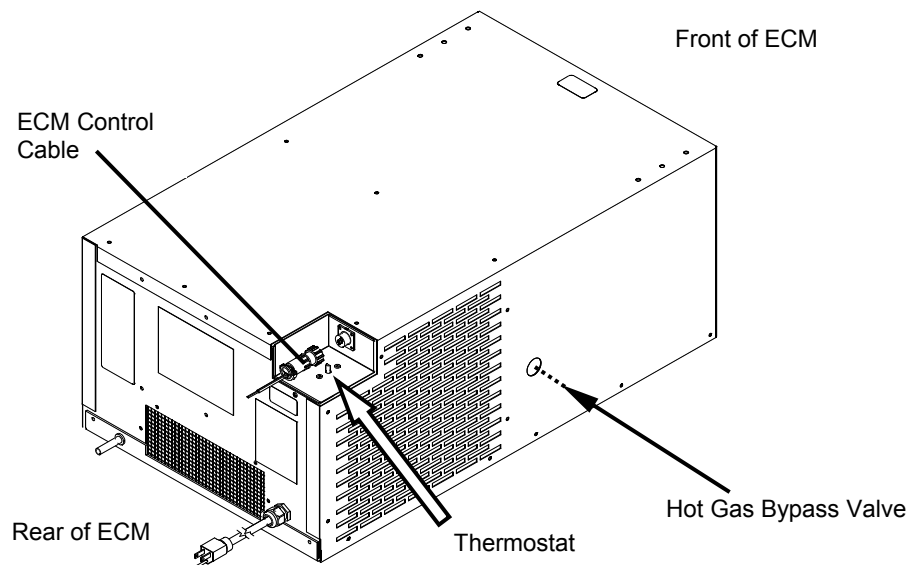

Figure 11 – ECM Adjustment Points

7.3 Investigating ECM Failure

7.3.1 Electrical Connections

Confirm that the ECM is connected to the proper electrical service. The ECM is not equipped with an on/off switch or control panel. The evaporator fan will continually circulate internal air through the cabinet, even when the compressor has cycled off. If the evaporator fan is not running, verify that the unit is connected to the proper electrical service as described in section 5.1. The ECM should not be powered from the internal UPS, as it will cause UPS overload and shutdown.

The ECM control cable must be installed on the rear of the ECM in order for the ECM to provide cooling. The standard control cable connector supplied with the ECM includes an internal jumper between pins 1 and 2 and an extended cord providing connection between pins 3 and 4. Refer to the CON1 connector in the ECM Schematic, Fig 8.2. The jumper between pins 1 and 2 is required to energize the compressor. The extended cord provides 24 VAC to the optional High Temperature Alarm Module, if installed.

The compressor is protected by an integral overload sensor (there is no external reset) and a 2-minute time delay relay, refer to the ECM Schematic, 163777. If the compressor is not running, but power is available and the control cable is connected, the ECM will need to be removed from the enclosure for troubleshooting. The thermostat, time delay relay, and R1 should be individually checked for continuity.

7.3.2 Removing the rack-mount ECM from the Enclosure

Tools required:

- 10mm or 11/32 socket and drive
- long (6") Phillips tip screwdriver
- small wire cutters

1. Unplug the ECM from the electric source.
2. To access the ECM, open the front door of the Foundation MCR and remove the two retaining bolts from the inside of the front access plate, located at the bottom of the rack. See diagram under Periodic Maintenance, section 4.4. The bolts require a 10mm socket, and are held in the frame by retaining clips to prevent them from falling inside the unit. The plate will swing down freely once the bolts are removed.
3. On 38-inch deep enclosures remove the condensate drain extension tube from the retaining bracket at the rear of the unit. On 30-inch deep enclosures, there is no extension tube on the condensate drain.
4. Disconnect the ECM Control Cable from the rear of the ECM and cut the wire ties to free the control cable.
5. With the long phillips tip screwdriver, remove the 4 screws from the ECM mounting brackets and remove the brackets from the enclosure.
6. Carefully remove the gasketing at the bottom front of the frame. Retain the Presstite insulation tape for re-installation. The ECM will now slide out the front of the enclosure.

7.3.3 Removing the top-mount ECM from the Enclosure

WARNING: The top-mount ECM is heavy (140 lbs/63.5kg). Before attempting to remove the assembly, make sure that the cabinet is stable and that at least one other person is able to assist with removal of the unit.

Tools required:

- 3/8" socket and drive
- long (6") Phillips tip screwdriver
- small wire cutters
- step ladder

1. Unplug the ECM from the electrical source.
2. Disconnect the ECM Control Cable from the rear of the ECM and cut the wire ties to free the control cable.
3. All 38" deep cabinets require the Top-Mount evaporator duct (item B in Figure 11). Remove the screws for this duct from the rear of the ECM.
4. The top-mount ECM assembly is secured to the frame with (8) hex bolts (item G in Figure 11). Remove these bolts from the inside of the enclosure.
5. Remove the entire top-mount ECM assembly (including the interface plenum) from the top of the enclosure.

Figure 12 – Top-Mount ECM Assembly

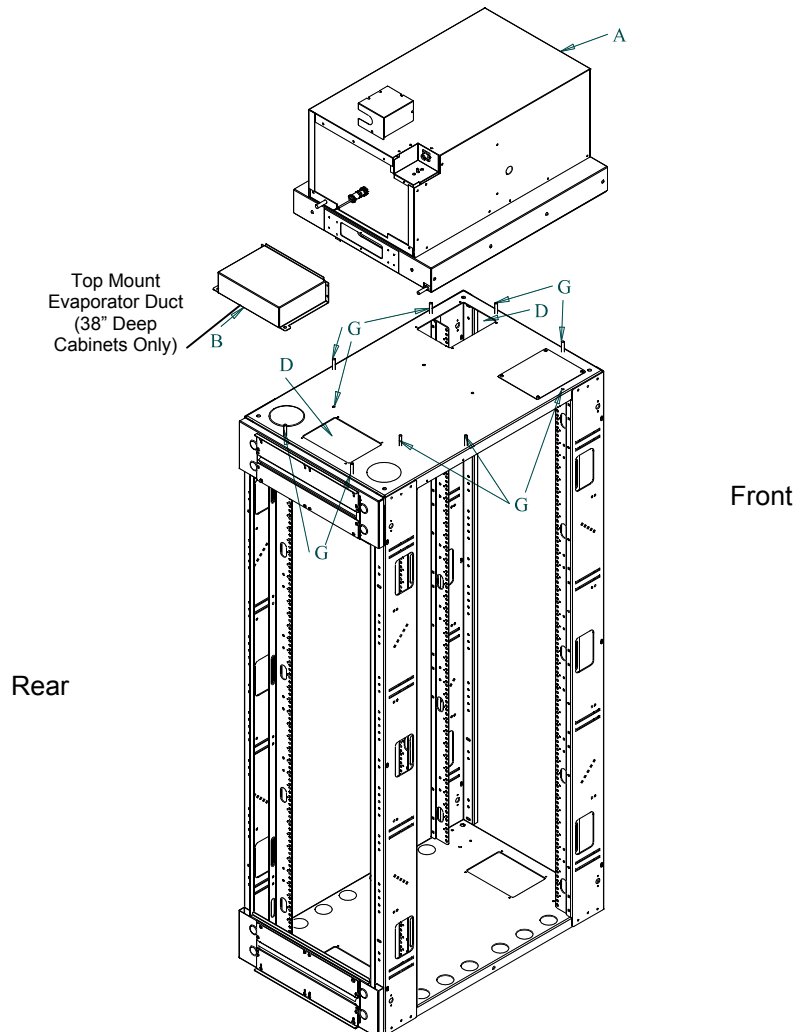

7.3.4 ECM Troubleshooting

Foundation ECM systems can be repaired to component level. Once removed from the enclosure, troubleshooting the ECM is similar to troubleshooting other Liebert environmental products. Place the ECM on a stable surface and remove the top cover plate. All of the screws on the top, front, and both sides of the ECM cover will need to be removed. The screws on the back of the ECM cover do not need to be removed.

Troubleshoot the unit's electrical system, and check for refrigerant leaks. If the compressor is not running, but power is available and the control cable is connected, the thermostat, time-delay relay, and relay R1 should be individually checked for continuity. The compressor is protected by an integral overload sensor (there is no external reset) and the 2-minute time delay relay. Refer to the system diagrams and schematics on the following pages.

The maximum charge level and the high & low pressure levels for each type of ECM are specified on the modules' serial tag, which is located on the rear of the ECM. Operating pressures will vary according to site and load conditions, typical operating conditions in most applications are 230–280 (high) and 55-75 (low). The ECM blowers and impellers do not require lubrication or periodic maintenance.

In the event that the entire ECM requires replacement, please consult Liebert DPG Applications Engineering at 1 800 222-5877 to confirm warranty status. Please be sure to include the model number and serial number of the Foundation MCR enclosure on all invoices returned to Liebert Corporation in order to complete processing. The model number and serial number for the Foundation MCR is located on the inside of the front left vertical frame.

7.3.5 REMOVING AND REPLACING DOORS OR SIDE PANELS

DOOR—REMOVING OR REVERSING

The doors available for the Foundation are removable for convenience when installing equipment. They also are reversible, enabling you to have the door open in a more convenient direction if it is near a wall or other equipment.

REMOVING THE DOOR

- Remove the bolts securing the lower half of each two-piece hinge to the door.
- Remove the lower half of each hinge.
- Lift the door straight up until the pins clear the hinges.
- Set the door in a safe place.

REVERSING THE DOOR

- After removing the door, take out the remaining bolts and screws to remove the top half of each hinge.
- Use a Phillips screwdriver to remove the four latches (two on the 44-inch unit).
- Attach the latches on the opposite side.
- Attach the top half of the hinges on the side where the latches had been.
- Rotate the door 180 degrees from its original position.
- Hang the door by inserting its pins into the hinges.
- Reattach the bottom half of the hinges.
- Reseal any holes that remain from previous installation.

REVERSING THE DOOR HANDLE

After the door has been reversed, the door handle of your Foundation will operate without adjustment, but it will be upside down. Should you wish to reverse the handle, follow these steps:

- Open the door and remove all the bolts holding the door handle and lock assembly, including

the four brackets (two on the 44-inch unit). Studs and nuts secure the brackets to the door frame.

- Flip the door handle and lock assembly 180 degrees and reattach it with the bolts and nuts.
- Check the handle and lock to ensure they operate properly.

SIDE PANELS—REMOVING / REPLACING

Foundation side panels are simple to remove and replace, making it easier to install equipment. Panel removal also improves access for maintaining or replacing equipment.

REMOVING A PANEL

- Inside the Foundation, locate the two security bolts in each side panel. (The security bolts are about halfway up the side of the panels, one is near the front edge of the panel and the other near the rear.)
- Remove the bolts with a 10mm wrench.
- Locate the four panel retainers on the outside of the Foundation panel. There is one retainer in each corner of the panel.
- Using the factory-supplied T-handle Allen wrench, turn the panel retainers 90 degrees counter-clockwise.
- Lift the panel off the lip at the bottom of the Foundation and set it in a safe location.

REPLACING A PANEL

- Set the panel on the lip at the bottom of the Foundation frame.
- Using the factory-supplied T-handle Allen wrench, turn each of the four panel retainers 90 degrees clockwise.
- For additional security, insert and tighten the two security bolts inside the Foundation, using a 10mm wrench.

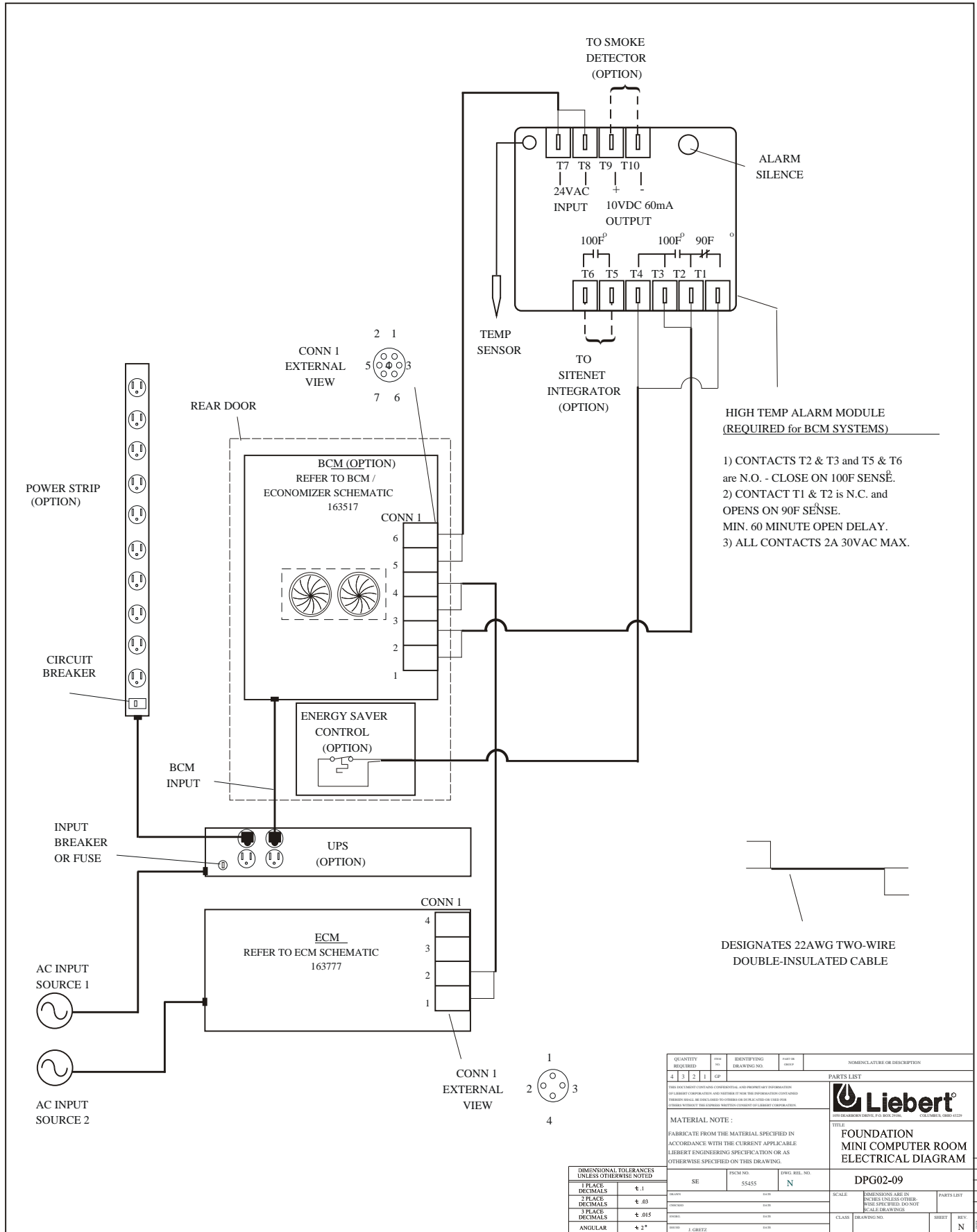

QUANTITY REQUIRED	REV	IDENTIFYING DRAWING NO.	DATE	NOMENCLATURE OR DESCRIPTION
4	3	2	1	GP
PARTS LIST				
<p>Liabert <small>FOUNDATION - DRIVE P.O. BOX 10000 - CHICAGO, ILLINOIS 60610-0000</small></p>				
<p>FOUNDATION MINI COMPUTER ROOM ELECTRICAL DIAGRAM</p>				
<p>DPG02-09</p>				
<p>SCALE: DIMENSIONS ARE IN INCHES UNLESS OTHERWISE SPECIFIED. DO NOT SCALE DRAWINGS</p>		<p>PARTS LIST</p>		
<p>CLASS: DRAWING NO.</p>		<p>SHEET: REV: N</p>		

DIMENSIONAL TOLERANCES UNLESS OTHERWISE NOTED	
1 PLACE DECIMALS	± .1
2 PLACE DECIMALS	± .03
3 PLACE DECIMALS	± .015
ANGULAR	± .2°

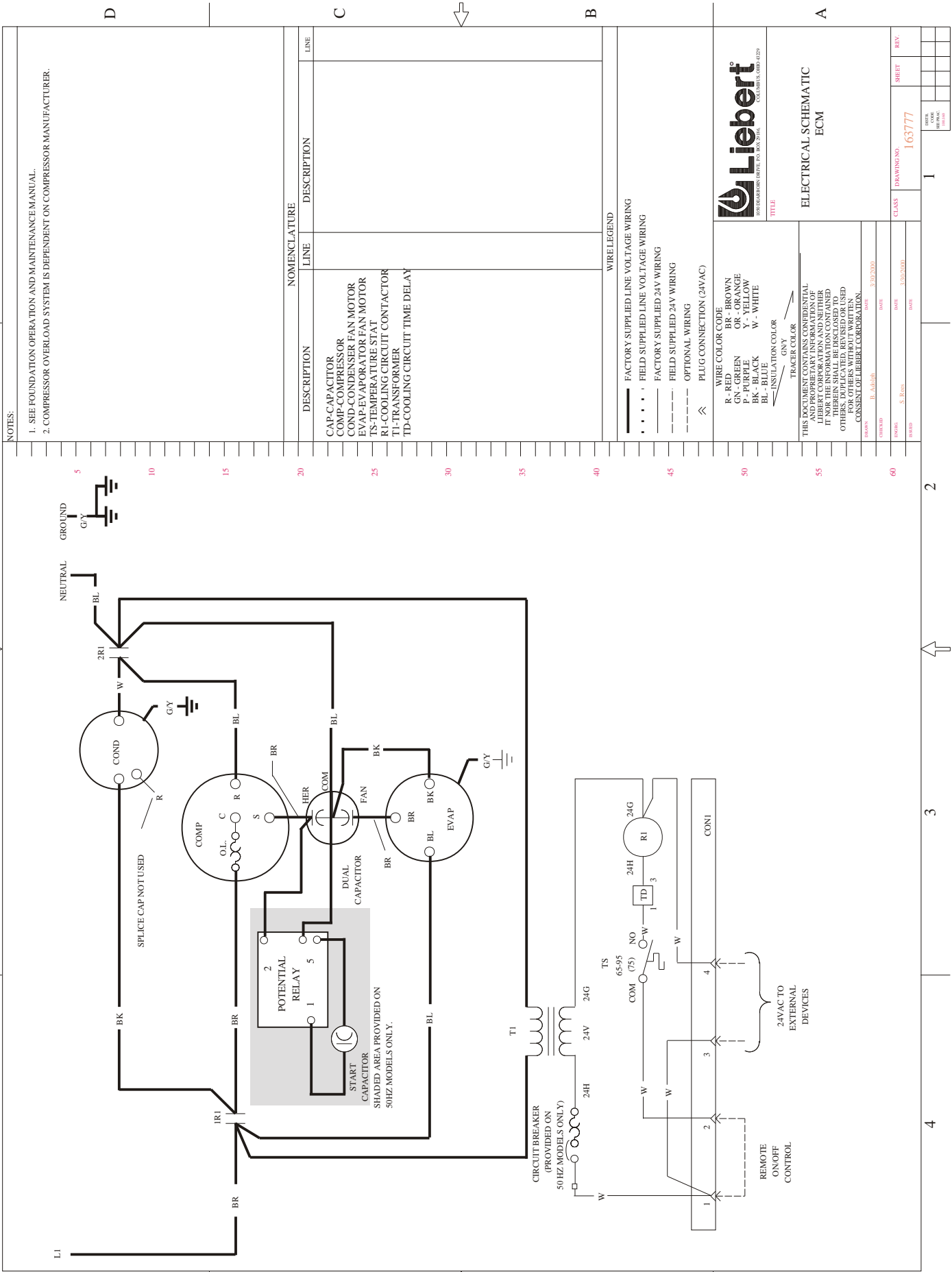

NOTES:
 1. SEE FOUNDATION OPERATION AND MAINTENANCE MANUAL.
 2. COMPRESSOR OVERLOAD SYSTEM IS DEPENDENT ON COMPRESSOR MANUFACTURER.

NOMENCLATURE	
DESCRIPTION	LINE
CAP. CAPACITOR	
COMP. COMPRESSOR	
COND. CONDENSER FAN MOTOR	
EVAP. EVAPORATOR FAN MOTOR	
TS. TEMPERATURE STAT.	
R. COOLING CIRCUIT CONTACTOR	
T1. TRANSFORMER	
TD. COOLING CIRCUIT TIME DELAY	

WIRE LEGEND	
—	FACTORY SUPPLIED LINE VOLTAGE WIRING
· · · · ·	FIELD SUPPLIED LINE VOLTAGE WIRING
---	FIELD SUPPLIED 24V WIRING
- - - - -	OPTIONAL WIRING
∧	PLUG CONNECTION (24VAC)

WIRE COLOR CODE	
R - RED	BR - BROWN
GN - GREEN	OR - ORANGE
BL - BLACK	GY - GREY
W - WHITE	

INSULATION COLOR	
GY	INSULATION COLOR
TRACER COLOR	

THIS DOCUMENT CONTAINS CONFIDENTIAL INFORMATION OF LIEBERT CORPORATION AND NEITHER LIEBERT CORPORATION NOR ANY OTHERS SHALL BE DISCLOSED OR USED FOR OTHERS WITHOUT WRITTEN CONSENT OF LIEBERT CORPORATION.

DATE	BY	CHKD	APP'D
3.10.2016	E. Ashish	S. Jeeva	



ELECTRICAL SCHEMATIC
 ECM

CLASS	DRAWING NO.	SHEET	REV.
	163777	1	

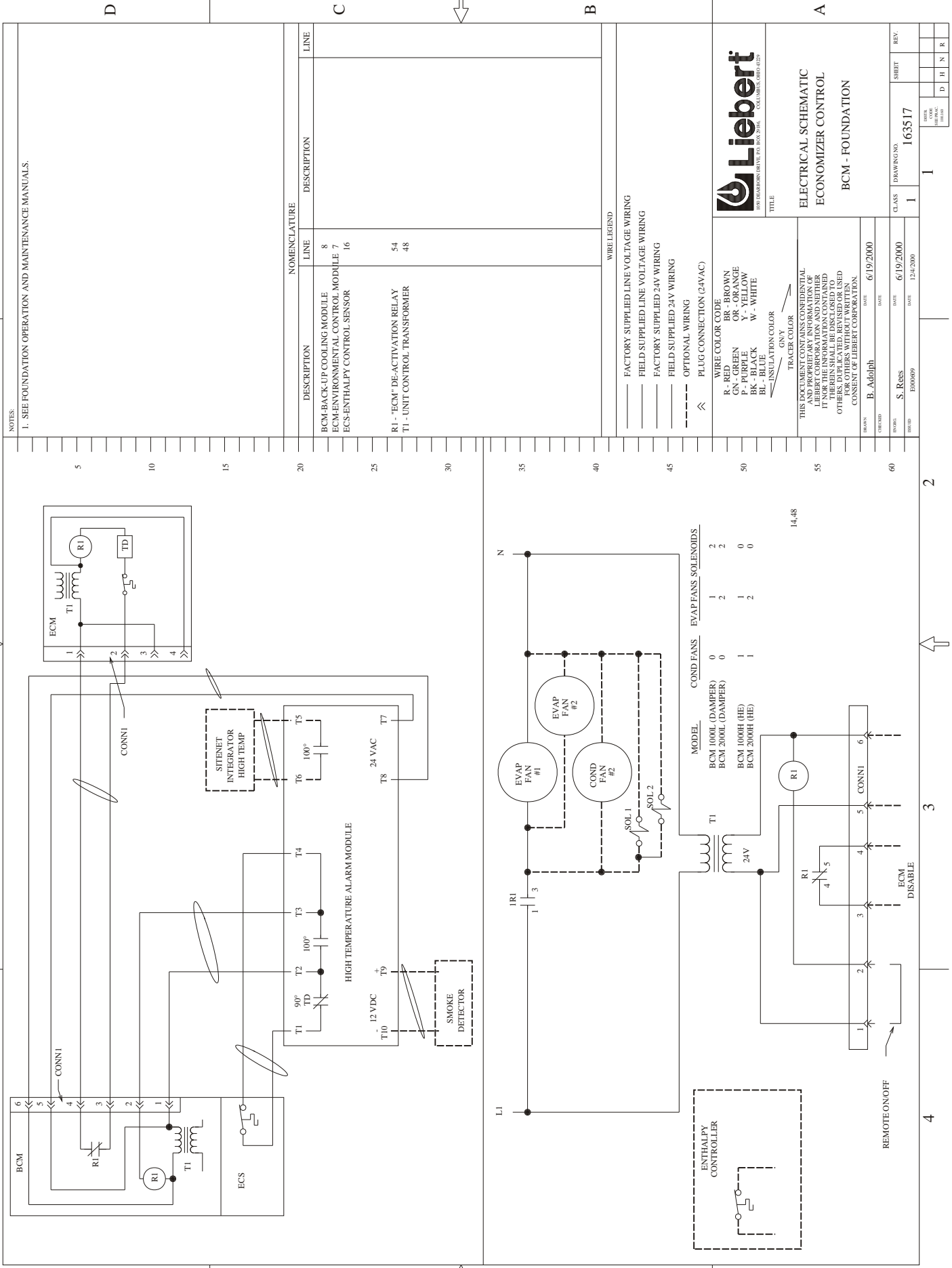

NOMENCLATURE	
DESCRIPTION	LINE
BCM-BACK-UP COOLING MODULE	8
ECM-ENVIRONMENTAL CONTROL MODULE	7
ECS-ENTHALPY CONTROL SENSOR	16
RI - "ECM" DE-ACTIVATION RELAY	54
TI - UNIT CONTROL TRANSFORMER	48

WIRE LEGEND	
FACTORY SUPPLIED LINE VOLTAGE WIRING	OPTIONAL WIRING
— (Solid line)	--- (Dashed line)
— (Dotted line)	--- (Dash-dot line)
— (Long-dashed line)	--- (Short-dashed line)
— (Dash-dot-dot line)	---

WIRE COLOR CODE	TRACER COLOR
R - RED	GNV
BR - BROWN	GNV
GN - GREEN	GNV
OR - ORANGE	GNV
P - PURPLE	GNV
Y - YELLOW	GNV
BK - BLACK	GNV
W - WHITE	GNV
INSULATION COLOR	GNV

DATE	BY	DATE	BY
6/19/2000	B. Adolph	6/19/2000	B. Adolph
6/19/2000	S. Reiss	12/24/2000	E000609



**ELECTRICAL SCHEMATIC
ECONOMIZER CONTROL
BCM - FOUNDATION**

CLASS	DRAWING NO.	SHEET	REV.
1	163517	1	

REV.	DATE	BY	CHK

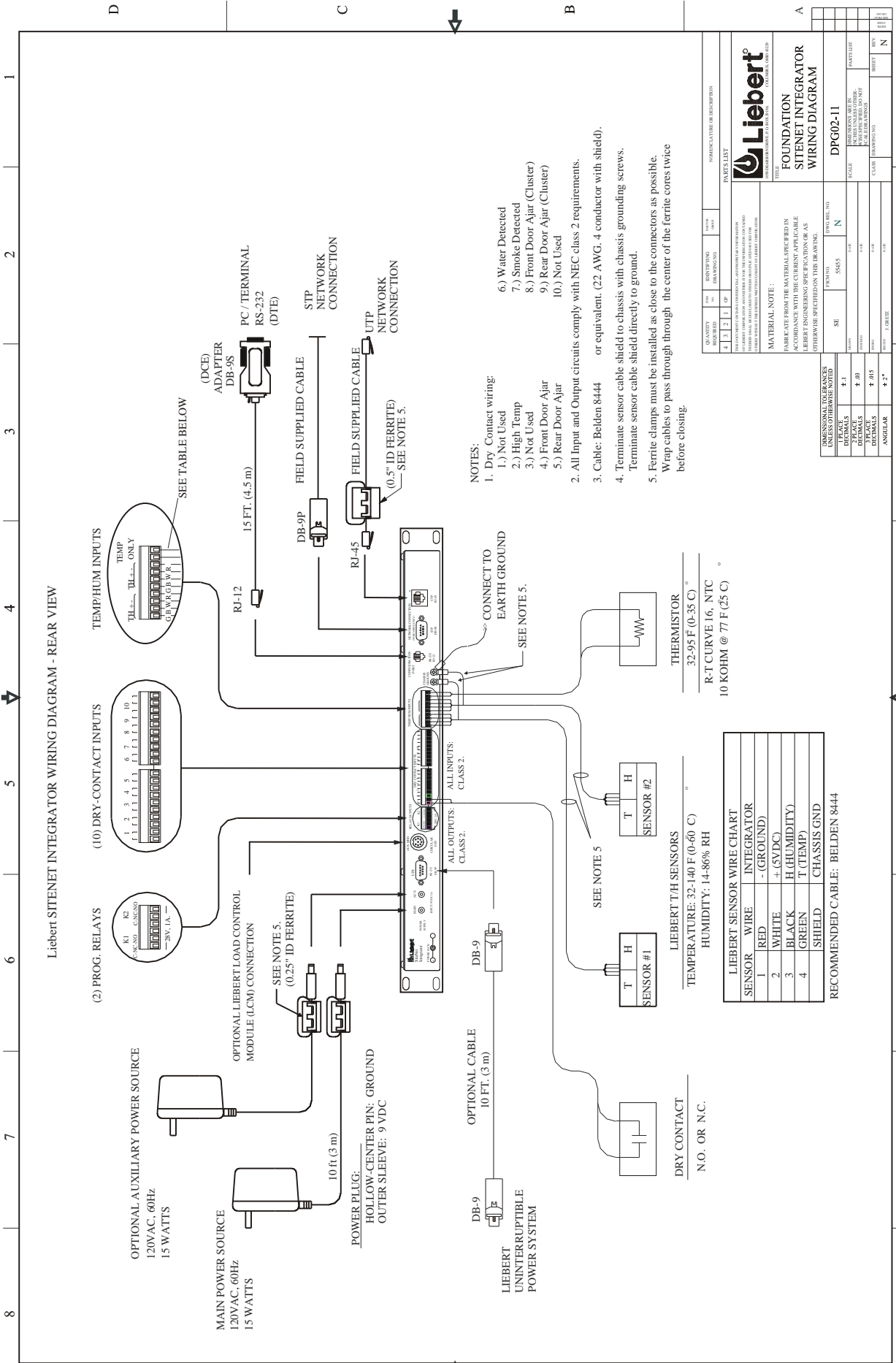

REV.	DESCRIPTION	DATE	APPROVED	REVISIONS

PART NUMBER	DESCRIPTION AND/OR MATERIAL																														
MATERIAL NOTE: FABRICATED FROM THE FACTORY SPECIFIED IN ACCORDANCE WITH THE CURRENT APPLICABLE IEEE ENGINEERING SPECIFICATION AS OTHERWISE NOTED ON THIS DRAWING.																															
THIRD ANGLE PROJECTION																															
<table border="1" style="width: 100%; border-collapse: collapse;"> <tr> <th colspan="2">DIMENSIONAL TOLERANCES UNLESS OTHERWISE SPECIFIED</th> <th colspan="2">FINISH</th> </tr> <tr> <td>SIZE OF HOLE</td> <td> </td> <td> </td> <td> </td> </tr> <tr> <td>PERFORATIONS</td> <td> </td> <td> </td> <td> </td> </tr> <tr> <td>PLATE THICKNESS</td> <td> </td> <td> </td> <td> </td> </tr> <tr> <td>FLAT SURFACES</td> <td> </td> <td> </td> <td> </td> </tr> <tr> <td>CHAMFERED</td> <td> </td> <td> </td> <td> </td> </tr> <tr> <td>ANGULAR</td> <td> </td> <td> </td> <td> </td> </tr> </table>				DIMENSIONAL TOLERANCES UNLESS OTHERWISE SPECIFIED		FINISH		SIZE OF HOLE				PERFORATIONS				PLATE THICKNESS				FLAT SURFACES				CHAMFERED				ANGULAR			
DIMENSIONAL TOLERANCES UNLESS OTHERWISE SPECIFIED		FINISH																													
SIZE OF HOLE																															
PERFORATIONS																															
PLATE THICKNESS																															
FLAT SURFACES																															
CHAMFERED																															
ANGULAR																															
<p>Liabert <small>IEEE REGULATORY COMPLIANCE DIVISION - COLUMBUS, OHIO 43229</small></p>																															
<p>FOUNDATION MCR ECM ASSEMBLY</p>																															
<p><small>THIS DOCUMENT CONTAINS CONFIDENTIAL AND PROPRIETARY INFORMATION OF LIEBERT CORPORATION AND SHOULD BE KEPT CONFIDENTIAL. THE INFORMATION CONTAINED HEREIN IS TO BE RELEASED TO OTHERS OR REPRODUCED FOR OTHERS WITHOUT THE WRITTEN PERMISSION OF LIEBERT CORPORATION.</small></p>																															
<p>ECM NO. 55485</p>																															
<p>DISTR. CODE</p>																															
<p>DRAWN: _____ DATE: _____</p>																															
<p>ENGR: _____ DATE: _____</p>																															
<p>ISSUED: _____ DATE: _____</p>																															
DWG. REL. NO.		CLASS	DRAWING NUMBER																												
			163710SYC																												
			SHEET 1																												
			REV. 1																												

REFER TO PARTS LISTS FOR CALLOUT DESIGNATIONS

DETAIL A

FRONT

REAR

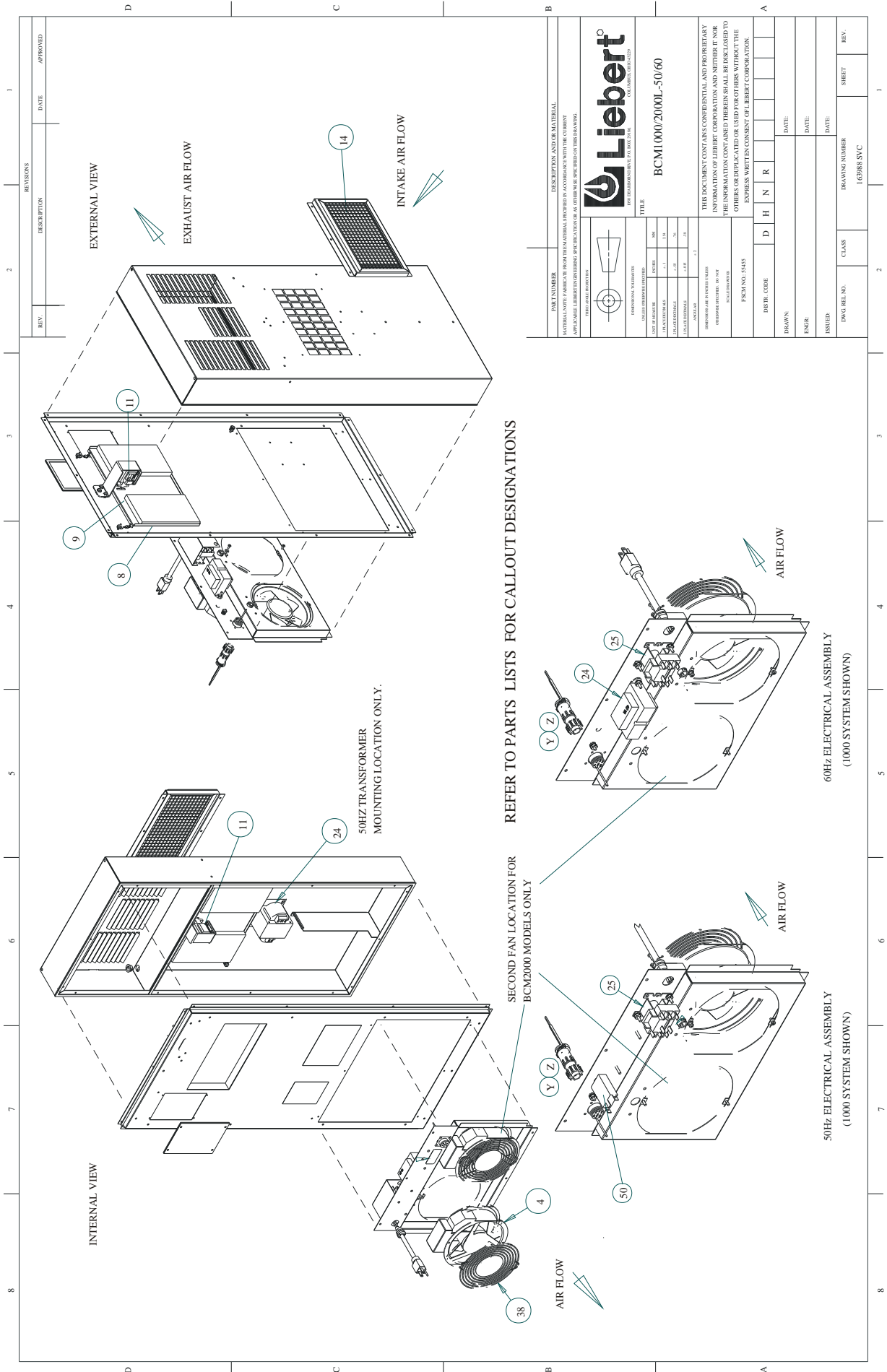

PART NUMBER		DESCRIPTION, AND/OR MATERIAL	
MATERIAL NOTE: FABRICATE FROM THE MATERIAL SPECIFIED IN ACCORDANCE WITH THE CURRENT APPLICABLE IEC/EN ENVIRONMENTAL SPECIFICATION AS OTHER THAN SPECIFIED ON THE DRAWING. THIS SHALL INCLUDE:			
THIS SHALL INCLUDE:		THIS SHALL INCLUDE:	
DIMENSIONAL PARAMETERS		DIMENSIONAL PARAMETERS	
UNIT OF MEASURE	VALUE	UNIT OF MEASURE	VALUE
LENGTH	MM	LENGTH	MM
ANGLE	DEG	ANGLE	DEG
AREA	CM ²	AREA	CM ²
VOLUME	CM ³	VOLUME	CM ³
WEIGHT	KG	WEIGHT	KG
OPERATIONAL PARAMETERS		OPERATIONAL PARAMETERS	
OPERATION AIR FLOW RATE	CMH	OPERATION AIR FLOW RATE	CMH
OPERATION TEMPERATURE	°C	OPERATION TEMPERATURE	°C
INSTALLATION		INSTALLATION	
FURNACE NO. 55455		FURNACE NO. 55455	
DISTR. CODE			
D	H	N	R
DATE:		DATE:	
DRAWN:		ENGR:	
ISSUED:		DATE:	
DWG. REL. NO.	CLASS	DRAWING NUMBER	REV.
16298K SVC			
SHEET	REV.		
1			



TITLE
BCM1000/2000L-50/60

THIS DOCUMENT CONTAINS CONFIDENTIAL AND PROPRIETARY INFORMATION OF LIBERT CORPORATION AND NEITHER IT NOR THE INFORMATION CONTAINED THEREIN SHALL BE DISCLOSED TO OTHERS OR REPRODUCED OR USED FOR OTHERS WITHOUT THE EXPRESS WRITTEN CONSENT OF LIBERT CORPORATION.

REFER TO PARTS LISTS FOR CALLOUT DESIGNATIONS

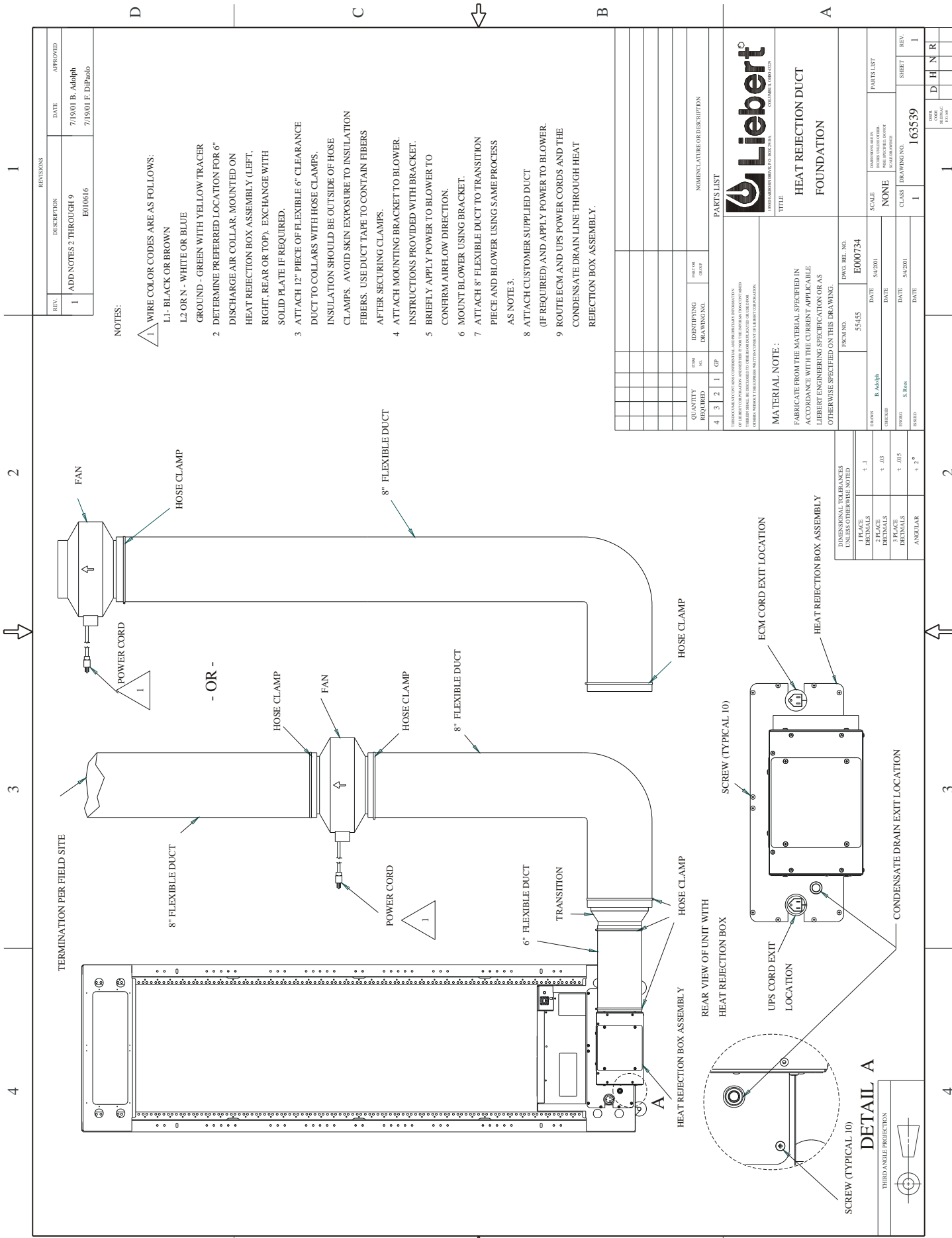

REVISIONS		DATE	APPROVED
1	ADD NOTES 2 THROUGH 9	7/19/01 B. Adolph	
		7/19/01 F. DiPaolo	

NOTES:

- 1 WIRE COLOR CODES ARE AS FOLLOWS:
L1 - BLACK OR BROWN
L2 OR N - WHITE OR BLUE
GROUND - GREEN WITH YELLOW TRACER
- 2 DETERMINE PREFERRED LOCATION FOR 6" DISCHARGE AIR COLLAR, MOUNTED ON HEAT REJECTION BOX ASSEMBLY (LEFT, RIGHT, REAR OR TOP). EXCHANGE WITH SOLID PLATE IF REQUIRED.
- 3 ATTACH 12" PIECE OF FLEXIBLE 6" CLEARANCE DUCT TO COLLARS WITH HOSE CLAMPS. INSULATION SHOULD BE OUTSIDE OF HOSE CLAMPS. AVOID SKIN EXPOSURE TO INSULATION FIBERS. USE DUCT TAPE TO CONTAIN FIBERS AFTER SECURING CLAMPS.
- 4 ATTACH MOUNTING BRACKET TO BLOWER. INSTRUCTIONS PROVIDED WITH BRACKET.
- 5 BRIEFLY APPLY POWER TO BLOWER TO CONFIRM AIRFLOW DIRECTION.
- 6 MOUNT BLOWER USING BRACKET.
- 7 ATTACH 8" FLEXIBLE DUCT TO TRANSITION PIECE AND BLOWER USING SAME PROCESS AS NOTE 3.
- 8 ATTACH CUSTOMER SUPPLIED DUCT (IF REQUIRED) AND APPLY POWER TO BLOWER.
- 9 ROUTE ECM AND UPS POWER CORDS AND THE CONDENSATE DRAIN LINE THROUGH HEAT REJECTION BOX ASSEMBLY.



TITLE
HEAT REJECTION DUCT FOUNDATION

SCALE	NONE	PARTS LIST	
DATE	5/4/2001	FORM NO. AND REV.	
DATE	5/4/2001	WORK SHEET NO. AND REV.	
DATE	5/4/2001	CLASS	DRAWING NO. 163539
DATE		REV	1

MATERIAL NOTE:
FABRICATE FROM THE MATERIAL SPECIFIED IN ACCORDANCE WITH THE CURRENT APPLICABLE LIEBERT ENGINEERING SPECIFICATION OR AS OTHERWISE SPECIFIED ON THIS DRAWING.

ITEM NO.	IDENTIFYING PART OR GROUP	QUANTITY REQUIRED	DESCRIPTION
4	1	1	GP

1 PLACE DECIMALS	± .1
2 PLACE DECIMALS	± .03
3 PLACE DECIMALS	± .015
ANGULAR	± 2°

9.0 Parts Lists

9.1 COMMON ECM PARTS – 120VAC 60Hz

Ckt Des.	Part Number	Description
0005	163631P1	IMPELLER EVAPORATOR BLOWER 115-1-60
0006	163640P1	BLOWER CONDENSER 115V 60HZ
0007	159463P3	XFMR 40VA 120-24 50/60HZ
0008	E-011B	CONTACTOR 2PL 24VCOIL 25
0010	138490P2	RELAY TIME DELAY 120SEC OFF DELAY
0011	163541P1	THERMOSTAT SPST 65-95F DIFF 5F
X	163772G1	ECM CONTROL CABLE
0028	141927P1	GASKET RUBBER TUBULAR#209
0045	168781G1	COVER RACK MOUNT ECM INSUL
0093	163993G1	HOT GAS BYPASS VALVE/SERP LINE ECM1000/2000
0094	163994G11	EVAP/FLTR LINE/VALVE TEV 3/8X3/8 ODF
0120	168159P1	SOUND JACKET INSUL

9.2 ECM1000 ONLY – 120VAC 60Hz

Ckt Des.	Part Number	Description
0009	163776P5	CAP DUAL 35 μ F/10 μ F 370VAC
0025	163996G1	COIL EVAP ECM 1000
0026	163998G1	COIL COND ECM 1000
0029	163693G1	COMPRESSOR ROTARY
N/A	152706P1	REFRIGERANT R-407C 1.13 lbs. (18oz)

9.3 ECM2000 ONLY – 120VAC 60Hz

Ckt Des.	Part Number	Description
0009	163776P3	CAP DUAL 30 μ F /10 μ F 370VAC
0025	163747G1	COIL EVAP ECM 2000
0026	163726G1	COIL COND ECM 2000
0029	163697G1	COMPRESSOR ROTARY
N/A	152706P1	REFRIGERANT R-407C 1.50 lbs. (24oz)

9.4 BCM COMMON PARTS – 120VAC 60Hz

Ckt Des.	Part Number	Description
0001	163987G1	PLATE ELEC ACCESS ASY
0004	5C10877P1	FAN 240CFM 115V
0007	163984G1	PLATE ASSY EXT/DOOR
0008	139525P3	GASKET MAGNETIC FRONT 6"
0009	163983P1	DOOR DAMPER BCM
0011	163990P1	SOLENOID 115VAC 60HZ
0013	163982P1	PLATE COVER REAR BCM
0014	140953P6	FILTER WIRE MESH 5.9X9.9X
0024	159463P3	XFMR 40VA 120-24 50/60HZ
0025	E-0130	RELAY 2P2T 24VAC COIL
Y	163516G1	WIRE HARNESS ENERGY SAVER CONTROL

9.5 ENTHALPY CONTROL – 120VAC 60Hz

Ckt Des.	Part Number	Description
N/A	163522G1	BCM ENERGY SAVER CONTROL KIT
0001	138401P1	CONTROLLER ENTHALPY MAKE ON INC
0005	E-0240	THERMOSTAT SPST 50/90F MAKE ON DEC
0010	163533G1	WIRE HARNESS REMOTE ENERGY SAVER CO

9.6 MISCELLANEOUS – 120VAC 60Hz

163774G1	HIGH TEMP ALARM (MODULE ONLY)
168605G1	HIGH TEMP ALARM MODULE with mounting plate/hardware

9.7 COMMON ECM PARTS – 230VAC 50Hz

Ckt Des.	Part Number	Description
0005	163631P2	IMPELLER EVAPORATOR BLOWER 230-1
0006	163640P2	BLOWER CONDENSER 230V 50HZ ECM
0007	147604P1	XFMR 75VA 208/230-24 50/6
0008	E-011B	CONTACTOR 2PL 24VCOIL 25/
0009	163776P2	CAP DUAL 15 μ F /2 μ F 370VAC
0010	138490P2	RELAY TIME DELAY 120SEC OFF DELAY
0011	163541P1	THERMOSTAT SPST 65-95F DIFF 5F
0012	141649G2	CORD PWR IEC320M 15' W/TE
X	163772G1	ECM CONTROL CABLE
0028	141927P1	GASKET RUBBER TUBULAR#209
0045	168781G1	COVER RACK MNT ECM INSUL
0093	163993G1	HOT GAS BYPASS VALVE/SERP LINE ECM1000/2000
0094	163994G11	EVAP/FLTR LINE/VALVE TEV 3/8X3/8 ODF ECM2000
0120	168159P1	SOUND JACKET INSUL

9.8 ECM1000 ONLY – 230VAC 50Hz

Ckt Des.	Part Number	Description
0025	163996G1	COIL EVAP MCR2 ECM 1000
0026	163998G1	COIL COND MCR2 ECM 1000
0029	163694G1	COMP ROTARY
N/A	152706P1	REFRIGERANT R-407C 1.19 lbs. (19oz)

9.9 ECM2000 ONLY – 230VAC 50Hz

Ckt Des.	Part Number	Description
0025	163747G1	COIL EVAP MCR2 ECM 2000
0026	163726G1	COIL COND MCR2 ECM 2000
0029	163698G1	COMP ROTARY
N/A	152706P1	REFRIGERANT R-407C 1.56 lbs. (25oz)

9.10 BCM COMMON PARTS – 230VAC 50Hz

Ckt Des.	Part Number	Description
0003	163535G1	WIRE HARNESS MCR 50HZ TRANS ADDS
0004	5C10877P2	FAN 240CFM 220/230VAC 50
0008	139525P3	GASKET MAGNETIC FRONT 6"
0011	163990P2	SOLENOID 230VAC 50HZ
0014	140953P6	FILTER WIRE MESH 5.9X9.9X
0019	141649P1	CORD PWR IEC320M 8' SJT14
0024	147604P1	XFMR 75VA 208/230-24 50
0025	E-0130	RELAY 2P2T 24VAC COIL
Y	163516G1	WIRE HARNESS ENERGY SAVER CONTROL

9.11 ENTHALPY CONTROL – 230VAC 50Hz

Ckt Des.	Part Number	Description
N/A	163522G1	BCM ENERGY SAVER CONTROL KIT
0001	138401P1	CONTROLLER ENTHALPY MAKE ON INC
0005	E-0240	THERMOSTAT SPST 50/90F MAKE ON DEC
0010	163533G1	WIRE HARNESS REMOTE ENERGY SAVER CO

9.12 MISCELLANEOUS – 230VAC 50Hz

	163774G1	HIGH TEMP ALARM MODULE
	168605G1	HIGH TEMP ALARM MODULE with mounting plate/hardware

10.0 Specifications

FAN PERFORMANCE DATA								
MODEL NUMBER	FANS	AIRFLOW	SOUND	INPUT POWER (1PH)				
	QTY	CFM	dBA	VAC	HZ	FLA	WSA	OPD
FAN1000L-60	1	114	47	120	60	0.2	0.3	15
FAN2000L-60	2	228	49	120	60	0.4	0.5	15
FAN1000L-50	1	94	45	230	50	0.1	0.2	10
FAN2000L-50	2	188	47	230	50	0.2	0.4	10
FAN1000H-60	1	235	59	120	60	0.3	0.4	15
FAN2000H-60	2	470	61	120	60	0.6	0.8	15
FAN1000H-50	1	200	57	230	50	0.1	0.1	10
FAN2000H-50	2	400	59	230	50	0.2	0.3	10

ECM PERFORMANCE DATA														
MODEL NUMBER	RATED SENSIBLE CAPACITY	SUPPORTED LOAD	MAX AMBIENT	HEIGHT	WIDTH	DEPTH	WEIGHT	TOTAL HEAT REJ.	INPUT POWER (1PH)					SOUND
	BTUH (WATTS)	BTUH (WATTS)	°F / °C	IN (MM) - U	IN (MM)	IN (MM)	LBS (KG)	BTUH (WATTS)	VAC	HZ	FLA	WSA	OPD	dBA (1.5 meters)
ECM1000L*-x60	5315 (1557)	2811 (824)	105°F / 41°C	12.25 (311) - 7	17.43 (443)	29 (737)	98 (44.5)	7146 (2094)	120	60	7.7	8.6	15	52
ECM1000L*-x50	5305 (1554)	2811 (824)	100°F / 38°C	12.25 (311) - 7	17.43 (443)	29 (737)	98 (44.5)	7698 (2255)	230	50	3.5	4.1	10	52
ECM2000L*-x60	6897 (2021)	5621 (1647)	105°F / 41°C	12.25 (311) - 7	17.43 (443)	29 (737)	101 (45.8)	10935 (3204)	120	60	10.9	11.7	15	52
ECM2000L*-x50	6708 (1965)	5621 (1647)	100°F / 38°C	12.25 (311) - 7	17.43 (443)	29 (737)	101 (45.8)	10375 (3040)	230	50	4.8	5.7	10	52

* = T (Top-Mount) and R (Rack-Mount).
 Top-Mount weight does not include interface plenum. The plenum for a 19" rack x 30" deep cabinet is 38 lbs.
 x = C (Carrier compressor) or T (Tecumseh compressor).
 Sound data based on sound pressure A-weighted scale for free field spherical radiation at 1.5 meters from cabinet.
 Sound data reflects only Rack-Mount design. Consult factory for Top-Mount data.

BCM PERFORMANCE DATA														
MODEL NUMBER	RATED SENSIBLE CAPACITY	SUPPORTED LOAD	MAX AMBIENT	HEIGHT	WIDTH	DEPTH	WEIGHT	TOTAL HEAT REJ.	INPUT POWER (1PH)					SOUND
	BTUH (WATTS)	BTUH (WATTS)	°F / °C	IN (MM)	IN (MM)	IN (MM)	LBS (KG)	BTUH (WATTS)	VAC	HZ	FLA	WSA	OPD	dBA (1.5 meters)
BCM 1000L-60	N/A	2811 (824)	105°F / 41°C	35.0 (889)	15.5 (393.7)	3.75 (95.2)	47 (21.3)	3038 (890)	120	60	1.0	1.3	15	57
BCM 1000L-50	N/A	2811 (824)	105°F / 41°C	35.0 (889)	15.5 (393.7)	3.75 (95.2)	47 (21.3)	3038 (890)	230	50	0.5	0.6	10	55
BCM 2000L-60	N/A	5621 (1647)	105°F / 41°C	35.0 (889)	15.5 (393.7)	3.75 (95.2)	50 (22.7)	5918 (1734)	120	60	2.0	2.5	15	59
BCM 2000L-50	N/A	5621 (1647)	105°F / 41°C	35.0 (889)	15.5 (393.7)	3.75 (95.2)	50 (22.7)	5918 (1734)	230	50	1.0	1.2	10	57

Above BCM weight includes rear door weight of 17 lbs.
 Sound data based on sound pressure A-weighted scale for free field spherical radiation at 1.5 meters from cabinet.

Job # _____ Invoice # _____ Start-Up Date _____

Liebert Foundation Mini Computer Room START-UP INSPECTION CHECK SHEET

The following information must be fully completed and returned to your local Liebert sales office to establish your equipment warranty. If your local Liebert sales office is not known, call 1 800-LIEBERT or check our website at www.liebert.com.

Start-Up Technician: _____ Company: _____

Telephone: (_____) - _____ Address: _____

SITE INFORMATION

Owner or Contact : _____ Company: _____

Telephone: (_____) - _____ Address: _____

ENCLOSURE MODEL #: _____ ENCLOSURE SERIAL #: _____

ECM MODEL #: _____ ECM SERIAL #: _____

BCM MODEL #: _____ BCM SERIAL # : _____

Was the unit received in good condition? Yes NO – Describe Damages: _____

If not, has the carrier been notified? Yes NO _____

Have the manuals been kept with the unit? Yes NO _____

INSPECTION CHECKLIST

I. SITE CONDITIONS

- ____ 1. Confirm at least 1'0.3m clearance in front & behind the unit. No side clearance required.
- ____ 2. Confirm at least 1'0.3m clearance above the top of the unit.
- ____ 3. Confirm service clearances: 3'1m enclosure front, or provisions to move enclosure to allow for service access.
- ____ 4. Confirm site ventilation provisions: ECM is self-contained air-cooled system.
 - Sufficient ambient space or airflow to dissipate the heat rejected by the ECM.
 - Ambient temperature range is 65°F (18°C) to 105°F (40°C).
 - If equipped with Heat Rejection Fan or Duct option, confirm electrical connection.
- ____ 5. Confirm ECM condensate drain tube is routed out the back of the unit, flex tube is clear and not kinked.
- ____ 6. Confirm separate dedicated circuits for ECM & UPS are provided (not same duplex).
 - ECMs require a 120V/60Hz/15A, single-phase 2-wire plus ground circuit.
 - Check UPS (if provided) nameplate for input electrical requirements.

Note if customer was advised to perform corrective actions to **Site Conditions**: _____

II. UNIT START-UP AND OPERATION

- 1. Confirm no ECM airflow obstructions:
 - External (1'0.3m minimum clearance): Enclosure front, rear and top
 - Internal: ECM discharge and return. Obstructions include manuals, cables, equipment overhanging shelves, etc.
- 2. Confirm the positioning of equipment inside the cabinet.
 - Prevent short cycling of ECM airflow - no large spaces between electronic devices in the top and bottom of the cabinet.
 - Equipment with the highest heat load should be located as close to the ECM as possible.
 - Heaviest equipment installed near the bottom of the cabinet.
- 3. Power up ECM: Apply power via the external cord/plug connection.
 - Confirm immediate internal ECM airflow: Inside enclosure, ECM right side (evap. discharge).
 - Confirm compressor engages within two minutes (return air must be $\geq 75F$ to start compressor).
- 4. Record the ECM working input voltage 120VAC ($\pm 10\%$): _____
- 5. Power up UPS (if provided). Record the UPS working input voltage (separate circuit): _____
- 6. Check BCM operation (if provided):
 - Check BCM power connection (120V/60Hz/15A)– plug into UPS output receptacle or external receptacle if no UPS provided.
 - Apply a temporary jumper between T2 and T3 (volt-free contact) on the High Temperature Alarm Module (located upper rear of enclosure); verify BCM damper doors open and fan(s) operate.
- 7. Check Cabinet Seals – No gaps, loose cables, air leaks:
 - Door gaskets intact / free of damage. Close front & rear doors and confirm no visible seal violations
 - Side panels and the frame have uniform sealing.
 - Cable entrance points are sealed.
- 8. Review operations guidelines (clearances, obstructions, etc.) and Preventative Maintenance with the user.

Note if customer was advised to perform corrective actions to **Unit Operation**: _____

Periodic Maintenance

The condenser intake should be inspected periodically to determine the necessary cleaning interval based on conditions at the installation site. Depending on site conditions, cleaning may be required as often as twice a month or as seldom as twice per year. The condenser is located at the bottom front of the enclosure. Clean the condenser by gently vacuuming with a soft bristle brush, or with compressed air. For rack-mounted ECM units, to access the condenser, open the front door of the MCR and remove the two retaining bolts from the inside of the front access plate at the bottom of the rack. The bolts require a 10mm socket or wrench. The plate will swing down freely once the bolts are removed. After cleaning, swing the access plate back into position and replace the bolts. For top-mounted ECM units, to access the condenser, shut down the ECM and remove the cover from the unit.

ADDITIONAL COMMENTS: _____

Return the completed Start-up form to your local Liebert representative office. To locate your local Liebert office, see the contacts link at www.liebert.com.

NOTES

NOTES

The Company Behind the Products

With over a million installations around the globe, Liebert is the world leader in computer protection systems. Since its founding in 1965, Liebert has developed a complete range of support and protection systems for sensitive electronics:

- Environmental systems—close-control air conditioning from 1 to 60 tons
- Power conditioning and UPS with power ranges from 300 VA to more than 1000 kVA
- Integrated systems that provide both environmental and power protection in a single, flexible package
- Monitoring and control—from systems of any size or location, on-site or remote
- Service and support through more than 100 service centers around the world and a 24/7 Customer Response Center

While every precaution has been taken to ensure the accuracy and completeness of this literature, Liebert Corporation assumes no responsibility and disclaims all liability for damages resulting from use of this information or for any errors or omissions.

© 2004 Liebert Corporation
All rights reserved throughout the world.
Specifications subject to change without notice.

® Liebert and the Liebert logo are registered trademarks of Liebert Corporation. All names referred to are trademarks or registered trademarks of their respective owners.

MCRSVC Rev. 1

Technical Support

United States

1050 Dearborn Drive
P.O. Box 29186
Columbus, OH 43229

Integrated Products / Single-Phase UPS
800-222-5877

Outside the United States
614-841-6755

3-Phase UPS
800-543-2378

Environmental Control
800-543-2778

Italy

Via Leonardo Da Vinci 8
Zona Industriale Tognana
35028 Piove Di Sacco (PD)
+39 049 9719 111
FAX: +39 049 5841 257

Asia

23F, Allied Kajima Bldg.
138 Gloucester Road
Wanchai
Hong Kong
+852 2 572 2201
FAX: +852 2 831 0114

Web Site
www.liebert.com